

Product Specification





	Model: GKTQ35SNAA1E0	Rev. No.	Issued Date.	Page.
		A	MAR.30.10	1 / 17

**Thin-Film-Transistor LCD Module
Model: GKTQ35SNAA1E0**

Acceptance

Solomon Goldentek Display Corp.
NO. 18 Ta-Yeh St., Ta-Fa Industrial Park, Ta-Liao
Hsiang, Kaohsiung Hsien 831, TAIWAN , R.O.C.
FAX: 886-7-7886800

Approved and Checked by

Approved by	Checked by		Made by
			

Product Specification

	Model: GKTQ35SNAA1E0	Rev. No.	Issued Date.	Page.
		A	MAR.30.10	2 / 17

Revise Records

Rev.	Date	Contents	Written	Approved
A	2010/04/30	Preliminary Specification	Kobe su	Sychang

Special Notes

Note1.	
Note2.	
Note3.	
Note4.	
Note5.	

Product Specification

	Model: GKTQ35SNAA1E0	Rev. No.	Issued Date.	Page.
		A	MAR.30.10	3 / 17

Contents

1	General Description and Features	4
1.1	Features	4
1.2	LCD Module	4
2	Mechanical Information	4
3	Electrical Specifications	5
3.1	Absolute Max. Ratings	5
3.2	Electrical Absolute Rating	6
4	Electrical Characteristics	7
4.1	TFT-LCD Module	7
4.2	Backlight Unit	7
5	Block Diagram	8
5.1	Interface System Structure with Back Light Unit	8
6	Input Terminal Pin Assignment	9
6.1	CN1 Pin Assignment (LCD)	9
7	Optical Characteristics	10
8	Basic Display Color and Gray Scale	13
8.1	Mapping for writing an Instruction	13
8.2	Mapping for writing an Pixel Data	13
9	AC CHARACTERISTICS	14
9.1	Parallel 8080 Timing Characteristics	14
10	TEST	16
11	Dimensional Outlines	17

Product Specification

	Model: GKTQ35SNAA1E0	Rev. No.	Issued Date.	Page.
		A	MAR.30.10	4 / 17

1 General Description and Features

GKQT35SNAA1E0 is a TM (Transmissive) type color active matrix TFT (Thin Film Transistor) liquid crystal display (LCD) that uses amorphous silicon TFT as a switching device. This model is composed of a TFT-LCD module, a driver circuit and a back-light unit. The resolution of a 3.5" contains 320RGBx240 dots and can display up to 65K/262K colors. The following table described the features of GKQT35SNAA1E0.

1.1 Features

- Transmissive and back-light with 6 LEDs are available.
- TN (Twisted Nematic) mode.
- 8 Bits i80 system interface

1.2 LCD Module

Item	Specification	Unit
Screen Size	3.5 inches	Diagonal
Display Resolution	320(H) x RGB x 240(V)	Dot
Pixel Pixels	0.073 (H) x 0.219 (V)	mm
Active Area	70.08 (H) x 52.56 (V)	mm
Outline Dimension	77.0 (W) x 64.0 (H) x 3.3 (D)	mm
Display Mode	Normally white/Transmissive	--
Pixel Arrangement	RGB Side-Stripe	--
Surface Treatment	Anti-glare (AG)	--
Display Color	65K/262K	--
Viewing Direction	6 o'clock (Gray Inversion)	--
TFT Driver	SSD2119Z7 or equivalent	--
Input Interface	8 Bits i80 system interface.	--

2 Mechanical Information

Item		Min.	Typ.	Max.	Unit	Note
Module Size	Horizontal (H)	76.7	77.0	77.3	mm	--
	Vertical (V)	63.7	64.0	64.3	mm	(1)
	Thickness (T)	3.15	3.3	3.45	mm	(1)
Weight		--	32	--	g	--

Note (1) Not include FPC.

Refer to the Dimensional Outlines for further information.

Product Specification

	Model: GKTQ35SNAA1E0	Rev. No.	Issued Date.	Page.
		A	MAR.30.10	5 / 17

3 Electrical Specifications

3.1 Absolute Max. Ratings

3.1.1 Absolute Ratings of Environment

If the operating condition exceeds the following absolute maximum ratings, the TFT LCD module may be damaged permanently.

(Ta=25±2°C, V_{SS}=GND=0)

Item	Symbol	Min.	Max.	Unit	Note
Storage temperature	T _{STG}	-30	80	°C	(1)
Operating temperature	T _{OPR}	-20	70	°C	(1,2,3)

Note (1) 95 % RH Max. (40 °C ≥ Ta). Maximum wet-bulb temperature at 39 °C or less. (Ta > 40 °C)
No condensation.

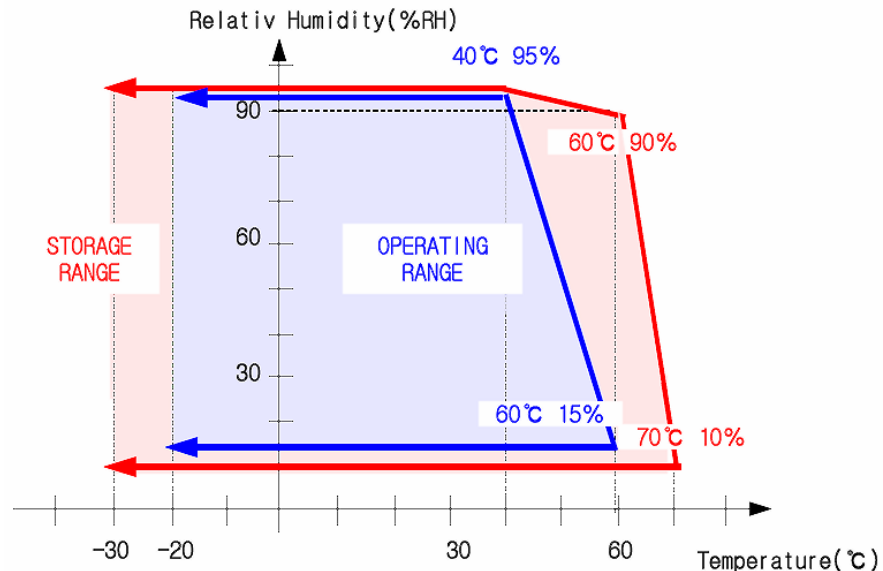

Note (2) In case of below 0°, the response time of liquid crystal (LC) becomes slower and the color of panel becomes darker than normal one. Level of retardation depends on temperature, because of LC's character

Note (3) Only operation is guaranteed at operating temperature. Contrast, response time, another display quality are evaluated at +25°C.

Product Specification

	Model: GKTQ35SNAA1E0	Rev. No.	Issued Date.	Page.
		A	MAR.30.10	6 / 17

3.2 Electrical Absolute Rating

3.2.1 TFT-LCD Module

(Ta=25±2°C, V_{SS}=GND=0)

Item	Symbol	Value		Unit	Condition
		Min.	Max.		
Logic power supply	V _{DDIO}	-0.3	4.0	V	--
Logic input voltage	V _{CI}	V _{SS} -0.3	5.0	V	--
Current Drain Per Pin Excluding VDD and VSS	I	--	25	mA	--

Note : Temp. ≤ 60°C, 90% RH MAX.

Temp. > 60°C , absolute humidity shall be less than 90% RH at 60°C

3.2.2 Back-Light Unit

(Ta=25±2°C)

Item	Symbol	Min.	Max.	Unit	Note
Current	I _f	--	30	mA	(1)

Note (1) Permanent damage to the device may occur if maximum values are exceeded or reverse voltage is loaded. Functional operation should be restricted to the conditions described under normal operating conditions.

Product Specification

	Model: GKTQ35SNAA1E0	Rev. No.	Issued Date.	Page.
		A	MAR.30.10	7 / 17

4 Electrical Characteristics

4.1 TFT-LCD Module

(Ta=25±2°C, V_{DDIO} =3.3V)

Item	Symbol	Value			Unit	Condition
		Min.	Typ.	Max.		
Power supply of IO pins	V _{DDIO}	1.4	--	3.6	V	
Booster Reference supply VoltageRange	V _{CI}	2.5 or V _{DDIO}	--	3.6	V	

4.2 Backlight Unit

The back-light system is an edge-lighting type with six white LED (Light Emitting Diode)s.

(Ta=25±2°C)

Item	Symbol	Value			Unit	Condition
		Min.	Typ.	Max.		
LED Voltage	VL	-	(19.2)	-	V	
LED Current	If	-	(20)	-	mA	
Power Consumption	P _{LED}	-	(384)	-	mW	
LED Life Time(25°C)	-	(20000)	-	-	hr	

Note (1) 6 LEDs serial type.

(2) Where If = 20mA, P_{LED} = V_F × I_B

Product Specification

	Model: GKTQ35SNAA1E0	Rev. No.	Issued Date.	Page.
		A	MAR.30.10	8 / 17

5 Block Diagram

5.1 Interface System Structure with Back Light Unit

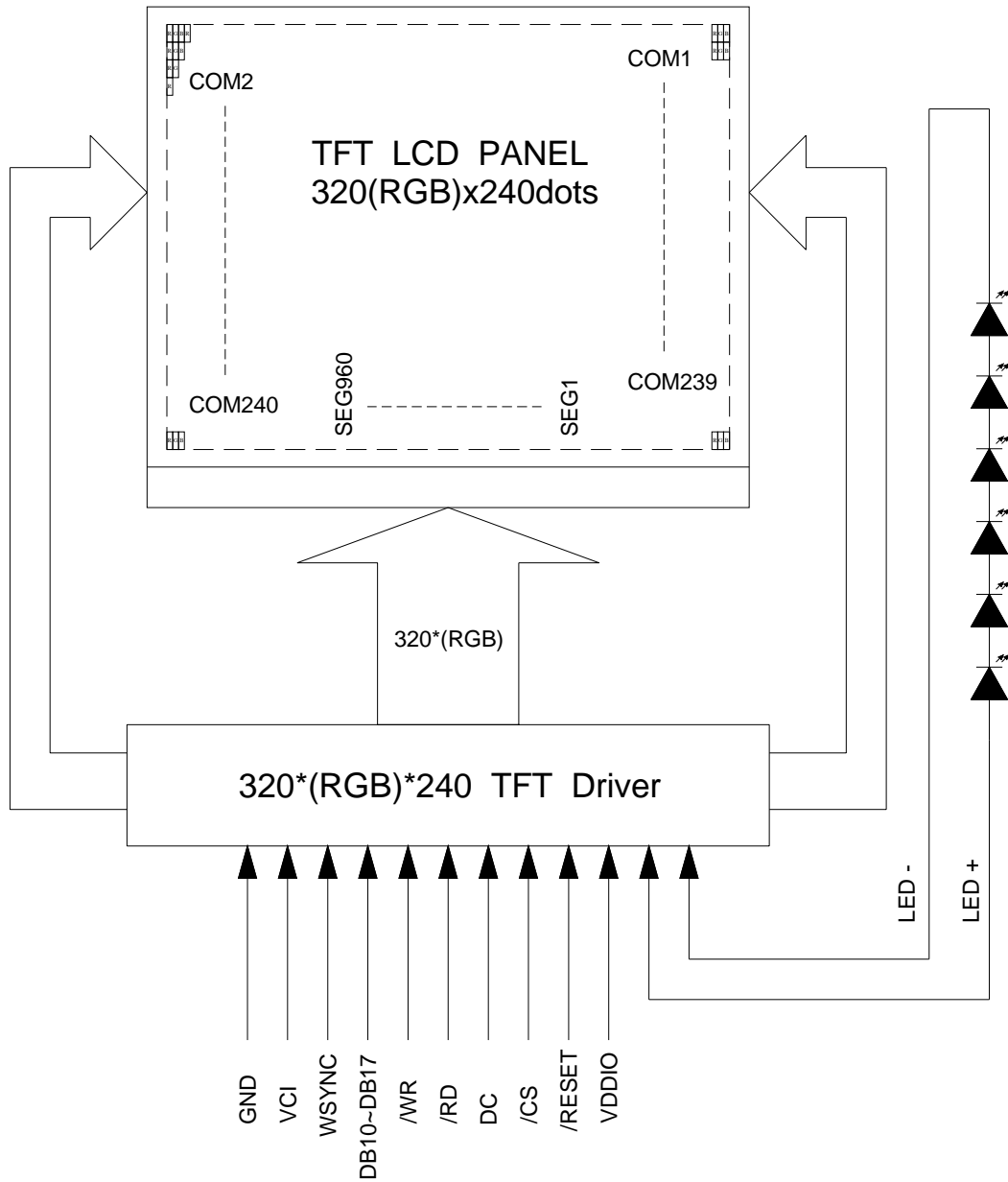

Product Specification

	Model: GKTQ35SNAA1E0	Rev. No.	Issued Date.	Page.
		A	MAR.30.10	9 / 17

6 Input Terminal Pin Assignment

6.1 CN1 Pin Assignment (LCD)

Pin No.	Symbol	I/O	Function
1	LED_A	P	Ground
2	LED_K	P	Ground
3	V _{DDIO}	P	Logic power supply(+3.0~3.6V)
4	NC	I/O	Not Connection
5~12	NC	I/O	Not Connection
13	NC	I/O	Not Connection
14~21	DB10~DB17	I/O	Data bus
22	WSYNC	O	Ram Write Synchronization output
23	GND	P	Ground
24	/CS	I	Chip select pin for 6800 Parallel Interface. Low: chip can be accessed; High: chip cannot be accessed.
25	/WR	I	Indicates read cycle when High, write cycle when Low)
26	/RD	I	Enable signal
27	DC	I	Parallel Interface
28	/RESET	P	Hardware Reset
29	V _{DDIO}	P	Logic power supply(+3.0~3.6V)
30	VCI	P	Booster input voltage pin. - Connect to voltage source between 2.5V to 3.6V
31	NC	I	Not Connection
32	NC	I	Not Connection
33	NC	I	Not Connection
34	NC	I	Not Connection
35	GND	P	Ground
36	GND	P	Ground

Product Specification

	Model: GKTQ35SNAA1E0	Rev. No.	Issued Date.	Page.
		A	MAR.30.10	10 / 17

7 Optical Characteristics

The following items are measured under stable conditions. The optical characteristics should be measured in a dark room or equivalent state with the methods shown in Note (1).
 Measuring equipment: BM-5A , BM-7

(Ta=25±2°C)

Item	Symbol	Condition	Min	Type	Max	Unit	Note
Brightness	--	--	(250)	(300)	--	cd/m ²	(1),(2)
Response time	T _R	θ=0°	--	(8)	(12)	ms	(1),(2)
	T _F		--	(17)	(23)	ms	
Contrast ratio	CR	At optimized viewing angle	(320)	(400)	--	--	(1)
Color Chromaticity	Red	R _X	(0.627)	(0.647)	(0.667)	--	(1)
		R _Y	(0.316)	(0.336)	(0.356)		
	Green	G _X	(0.29)	(0.31)	(0.33)	--	
		G _Y	(0.556)	(0.576)	(0.596)		
	Blue	B _X	(0.116)	(0.136)	(0.156)	--	
		B _Y	(0.109)	(0.129)	(0.149)		
	White	W _X	(0.287)	(0.307)	(0.327)	--	
		W _Y	(0.335)	(0.355)	(0.375)		
Viewing Angle (6H)	Hor.	θ	(90)	(100)	--	Degree	(1)
	Ver.	φ	(110)	(120)	--		

Product Specification

	Model: GKTQ35SNAA1E0	Rev. No.	Issued Date.	Page.
		A	MAR.30.10	11 / 17

a. Test equipment setup

After stabilizing and leaving the panel alone shall be warmed up for the stable operation of LCM, the measurement should be executed. Measurement should be executed in a stable, windless, and dark room. Optical specifications are measured by Topcon BM-7(fast) with a viewing angle of 2° at a distance of 50cm and normal direction.

b. Definition of response time: Tr and Tf

The response time is defined as the following figure and shall be measured by switching the input signal for "black" and "white".

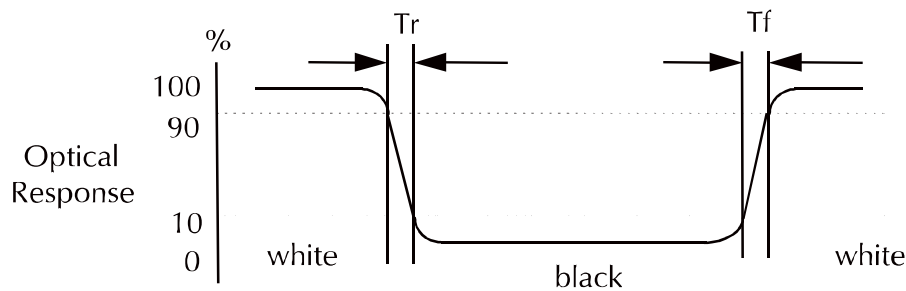

c. Definition of contrast ratio:

Brightness measured when LCD is at "white state"

$$\text{Contrast Ratio (CR)} = \frac{\text{Brightness measured when LCD is at "white state"}}{\text{Brightness measured when LCD is at "black state"}}$$

Brightness measured when LCD is at "black state"

d. Measured at the center area of the panel when all the input terminals of LCD panel are electrically opened.

Product Specification

	Model: GKTQ35SNAA1E0	Rev. No.	Issued Date.	Page.
		A	MAR.30.10	12 / 17

e. View Angle

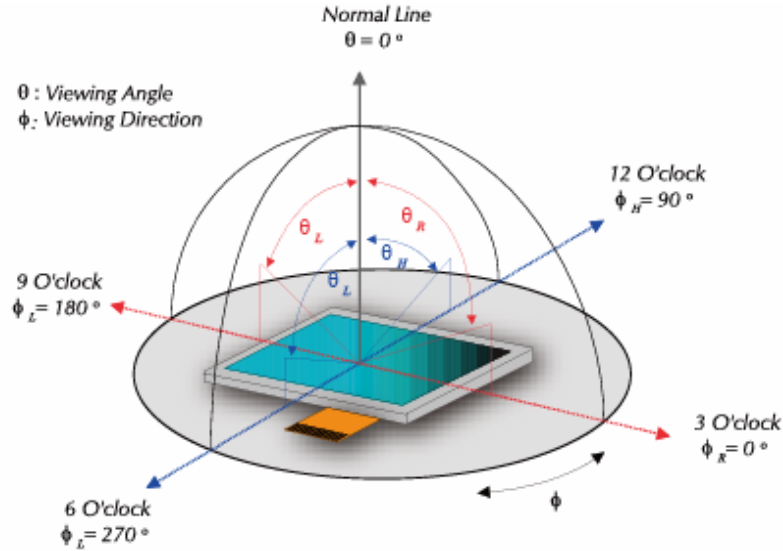

f. Definition of Luminance of White: Luminance of white at the center points

Light Source of Back-Light Unit	LED Type
---------------------------------	----------

g. Definition of White Uniformity

$$\text{White Uniformity} = \frac{\text{Min. luminance of white among 9-points}}{\text{Max. luminance of white among 9-points}}$$

h. The definition of Color Gamut -Color Chromaticity CIE 1931

Color coordinate of white & red, green, blue at center point.

Color Gamut : NTSC(%) = (RGB Triangle Area / NTSC Triangle Area) x 100

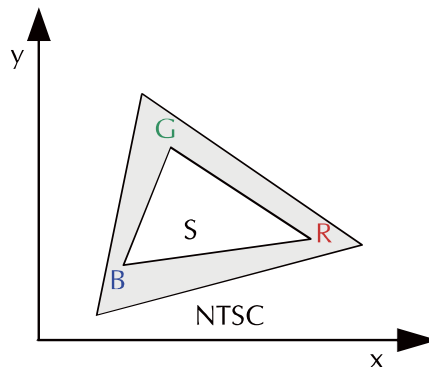

Product Specification



Model: GKTQ35SNAA1E0

Rev. No.

Issued Date.

Page.

A

MAR.30.10

13 / 17

8 Basic Display Color and Gray Scale

8.1 Mapping for writing an Instruction

		Hardware pins																	
Interface	Cycle	D17	D16	D15	D14	D13	D12	D11	D10	D9	D8	D7	D6	D5	D4	D3	D2	D1	D0
18 bits		IB15	IB14	IB13	IB12	IB11	IB10	IB9	IB8	x	IB7	IB6	IB5	IB4	IB3	IB2	IB1	IB0	x
16 bits		IB15	IB14	IB13	IB12	IB11	IB10	IB9	IB8		IB7	IB6	IB5	IB4	IB3	IB2	IB1	IB0	
9 bits	1 st	IB15	IB14	IB13	IB12	IB11	IB10	IB9	IB8	x									
	2 nd	IB7	IB6	IB5	IB4	IB3	IB2	IB1	IB0	x									
8 bits	1 st	IB15	IB14	IB13	IB12	IB11	IB10	IB9	IB8										
	2 nd	IB7	IB6	IB5	IB4	IB3	IB2	IB1	IB0										

Remark : x Don't care bits
 Not connected pins

8.2 Mapping for writing an Pixel Data

			Hardware pins																	
Interface	Color mode	Cycle	D17	D16	D15	D14	D13	D12	D11	D10	D9	D8	D7	D6	D5	D4	D3	D2	D1	D0
18 bits	262k		R5	R4	R3	R2	R1	R0	G5	G4	G3	G2	G1	G0	B5	B4	B3	B2	B1	B0
16 bits	262k	1 st	R5	R4	R3	R2	R1	R0	x	x		G5	G4	G3	G2	G1	G0	x	x	
		2 nd	B5	B4	B3	B2	B1	B0	x	x		R5	R4	R3	R2	R1	R0	x	x	
		3 rd	G5	G4	G3	G2	G1	G0	x	x		B5	B4	B3	B2	B1	B0	x	x	
		1 st	R5	R4	R3	R2	R1	R0	x	x		G5	G4	G3	G2	G1	G0	x	x	
		2 nd	x	x	x	x	x	x	x	x		B5	B4	B3	B2	B1	B0	x	x	
		1 st	R5	R4	R3	R2	R1	R0	x	x		G5	G4	G3	G2	G1	G0	x	x	
9 bits	262k	1 st	R5	R4	R3	R2	R1	R0	G5	G4	G3									
		2 nd	G2	G1	G0	B5	B4	B3	B2	B1	B0									
8 bits	262k	1 st	R5	R4	R3	R2	R1	R0	x	x										
		2 nd	G5	G4	G3	G2	G1	G0	x	x										
	3 rd	B5	B4	B3	B2	B1	B0	x	x											
	65k	1 st	R4	R3	R2	R1	R0	G5	G4	G3			G2	G1	G0	B4	B3	B2	B1	B0
2 nd		G2	G1	G0	B4	B3	B2	B1	B0											

Remark : x Don't care bits
 Not connected pins

Product Specification

	Model: GKTQ35SNAA1E0	Rev. No.	Issued Date.	Page.
		A	MAR.30.10	14 / 17

9 AC CHARACTERISTICS

9.1 Parallel 8080 Timing Characteristics

(Ta=25 ±2°C , V_{DDIO} =3.3V)

Item	Symbol	Min.	Typ.	Max.	Unit
Clock Cycle Time (write cycle)	t _{cycle}	75	-	-	n _{Se}
Clock Cycle Time (read cycle)	t _{cycle}	1000	-	-	n _{Se}
Address Setup Time (R/W)	t _{AS}	0	-	-	n _{Sec}
Address Hold Time (R/W)	t _{AH}	0	-	-	n _{Se}
Data Setup Time (D0~D7,WRITE)	t _{DSW}	5	-	-	n _{Se}
Data Hold Time (D0~D7,WRITE)	t _{DHW}	5	-	-	n _{Se}
Data Access Time (D0~D7,READ)	t _{ACC}	250	-	-	n _{Se}
Output Hold time (D0~D7,READ)	t _{OH}	100	-	-	n _{Se}
Pulse width /CS low (write cycle)	RW _{CSL}	40	-	-	n _{Sec}
Pulse width /CS high (write cycle)	RW _{CSH}	25	-	-	n _{Sec}
Pulse width /CS low (write cycle)	RW _{CSL}	500	-	-	n _{Sec}
Pulse width /CS high (write cycle)	RW _{CSH}	500	-	-	n _{Sec}
Rise time (/CS)	t _R	-	-	4	n _{Se}
Fall time (/CS)	t _F	-	-	4	n _{Sec}

Write Cycle

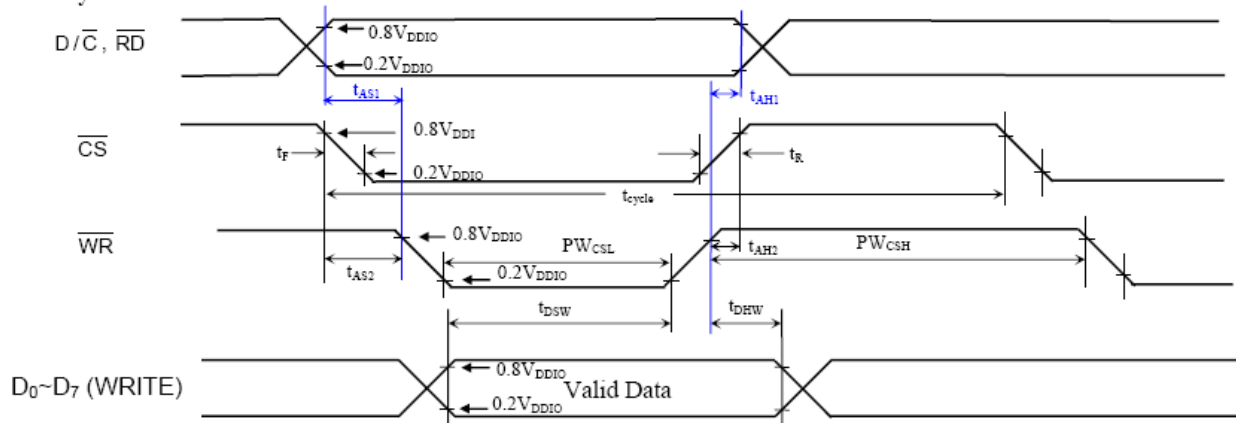

Remark: It's highly recommended that \overline{RD} remains high for the whole write cycle

Product Specification

	Model: GKTQ35SNAA1E0	Rev. No.	Issued Date.	Page.
		A	MAR.30.10	15 / 17

Read Cycle

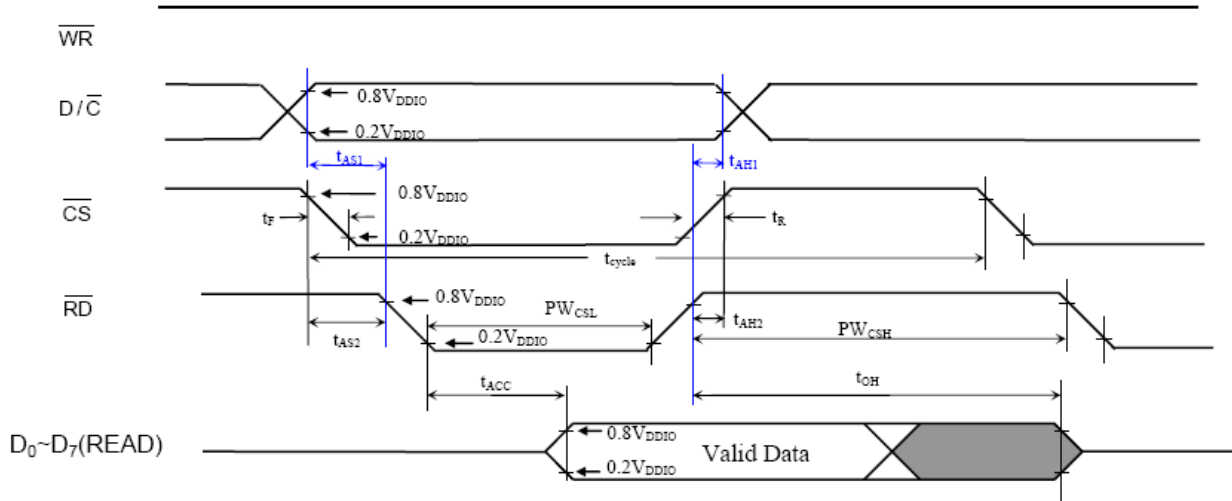

Product Specification

	Model: GKTQ35SNAA1E0	Rev. No.	Issued Date.	Page.
		A	MAR.30.10	16 / 17

10 TEST

No change on display and in operation under the following test condition.

Condition: Unless otherwise specified, tests will be conducted under the following condition.

Temperature: 20±5°C.

Humidity: 65±5%RH.

Tests will be not conducted under functioning state.

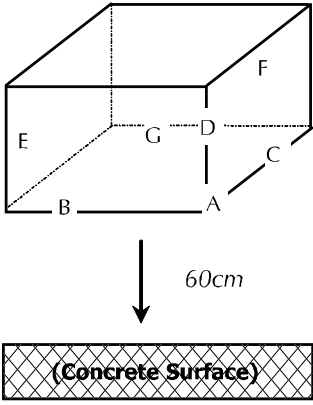
No.	Parameter	Condition	Notes
1	High Temperature Operating	70°C±2°C, 240hrs (Operation state).	
2	Low Temperature Operating	-20°C±2°C, 240hrs (Operation state).	1
3	High Temperature Storage	80°C±2°C, 240hrs.	2
4	Low Temperature Storage	-30°C±2°C, 240hrs.	1,2
5	High Temperature and High Humidity Operation Test	60°C±2°C, 90%, 240hrs	1,2
6	Vibration Test	Total fixed amplitude: 1.5mm. Vibration Frequency: 10~55Hz. One cycle 60 seconds to 3 direction of X, Y, Z each 15 minutes.	3
7.	Drop Test	To be measured after dropping from 60cm high on the concrete surface in packing state.  <p style="color: blue; margin-left: 20px;"><i>Dropping method corner dropping:</i></p> <p style="color: blue; margin-left: 20px;"><i>A corner: Once edge dropping.</i></p> <p style="color: blue; margin-left: 20px;"><i>B, C, D edge: Once face dropping.</i></p> <p style="color: blue; margin-left: 20px;"><i>E, F, G face: Once.</i></p>	

- Notes:
1. No dew condensation to be observed.
 2. The function test shall be conducted after 4 hours storage at the normal temperature and humidity after removed from the test chamber.
 3. Vibration test will be conducted to the product itself without putting I in a container.

Product Specification



Model: GKTQ35SNAA1E0

Rev. No.

Issued Date.

Page.

A

MAR.30.10

17 / 17

11 Dimensional Outlines

