

**Product Specification**



Model: GKTY43SPAH4R0

Rev. No.

Issued Date.

Page.

A

2010,NOV,30

1 / 20

**Thin-Film-Transistor LCD Module  
Model: GKTY43SPAH4R0**

Acceptance

**Solomon Goldentek Display Corp.**

**NO. 18 Ta-Yeh St., Ta-Fa Industrial Park, Ta-Liao  
Hsiang, Kaohsiung Hsien 831, TAIWAN , R.O.C.  
FAX: 886-7-7886800**

Approved and Checked by

Approved by	Checked by		Made by



## Product Specification

	Model: GKTY43SPAH4R0	Rev. No.	Issued Date.	Page.
		A	2010,NOV,30	3 / 20

## Contents

<b>1</b>	<b>General Description and Features</b> .....	<b>4</b>
1.1	Features	4
1.2	LCD Module	4
<b>2</b>	<b>Mechanical Information</b> .....	<b>5</b>
<b>3</b>	<b>Electrical Specifications</b> .....	<b>6</b>
3.1	Absolute Max. Ratings	6
3.2	Electrical Absolute Rating	6
<b>4</b>	<b>Touch Screen Panel Specifications</b> .....	<b>7</b>
<b>5</b>	<b>Electrical Characteristics</b> .....	<b>8</b>
5.1	TFT-LCD Module	8
5.2	Backlight Unit	8
<b>6</b>	<b>Block Diagram</b> .....	<b>9</b>
<b>7</b>	<b>Input Terminal Pin Assignment</b> .....	<b>10</b>
7.1	CN1 Pin Assignment	10
<b>8</b>	<b>Optical Characteristics</b> .....	<b>12</b>
<b>9</b>	<b>Basic Display Color and Gray Scale</b> .....	<b>15</b>
<b>10</b>	<b>AC Timing</b> .....	<b>16</b>
10.1	AC Characteristics	16
10.2	Parallel RGB Input Timing Table (SYNC MODE)	17
10.3	POWER ON/OFF SEQUENCE	18
<b>11</b>	<b>Test</b> .....	<b>19</b>
<b>12</b>	<b>Dimensional outlines</b> .....	<b>20</b>

## Product Specification

	Model: GKTY43SPAH4R0	Rev. No.	Issued Date.	Page.
		A	2010,NOV,30	4 / 20

### 1 General Description and Features

GKTY43SPAH4R0 is a TM (Transmissive) type color active matrix TFT (Thin Film Transistor) liquid crystal display (LCD) that uses amorphous silicon TFT as a switching device. This model is composed of a TFT-LCD module, a driver circuit and a back-light unit and Touch panel. The resolution of a 4.3" contains 480(RGB)x272 dots and can display up to 16.7M colors. The following table described the features of GKTY43SPAH4R0.

#### 1.1 Features

- Transmissive and back-light with 7 LEDs are available.
- TN (Twisted Nematic) mode.
- 24bit RGB Interface
- 4-wire Touch panel
- ROHS Compliance

#### 1.2 LCD Module

Item	Specification	Unit
Screen Size	4.3 inches	Diagonal
Display Resolution	480(H) x RGB x 272(V)	Dot
Pixel size	0.198 (H) x 0.198 (V)	mm
Active Area	95.040 (H) x 53.856 (V)	mm
Outline Dimension	105.5 (W) x 67.2 (H) x 5.05 (D)	mm
Display Mode	Normally white/Transmissive	--
Pixel Arrangement	RGB Vertical-Stripe	--
Surface Treatment	Anti-glare (AG)	--
Display Color	16.7M	--
Viewing Direction (Gray Inversion)	6 o'clock (Gray Inversion)	--
Input Interface	Digital 24-bits parallel RGB	--
Color Gamut (NTSC%)	NTSC 48%	--



## Product Specification

	Model: GKTY43SPA4R0	Rev. No.	Issued Date.	Page.
		A	2010,NOV,30	6 / 20

### 3 Electrical Specifications

#### 3.1 Absolute Max. Ratings

##### 3.1.1 Absolute Ratings of Environment

If the operating condition exceeds the following absolute maximum ratings, the TFT LCD module may be damaged permanently.

(Ta=25±2°C, V<sub>SS</sub>=GND=0)

Item	Symbol	Min.	Max.	Unit	Note
Storage temperature	T <sub>STG</sub>	-30	80	°C	(1)
Operating temperature	T <sub>OPR</sub>	-20	70	°C	(1,2,3)

Note (1) 95 % RH Max. ( 40 °C ≥ Ta ). Maximum wet-bulb temperature at 39 °C or less. (Ta > 40 °C) No condensation.

Note (2) In case of below 0°, the response time of liquid crystal (LC) becomes slower and the color of panel becomes darker than normal one. Level of retardation depends on temperature, because of LC's character

Note (3) Only operation is guaranteed at operating temperature. Contrast, response time, another display quality are evaluated at +25°C.

#### 3.2 Electrical Absolute Rating

##### 3.2.1 TFT-LCD Module

(Ta=25±2°C, V<sub>SS</sub>=GND=0)

Item	Symbol	Value		Unit	Condition
		Min.	Max.		
Power supply voltage	DV <sub>DD</sub>	-0.3	4.5	V	

##### 3.2.2 Back-Light Unit

(Ta=25±2°C)

Item	Symbol	Min.	Max.	Unit	Note
Current of One LED	I <sub>B</sub>	--	(25)	mA	(1)

Note (1) Permanent damage to the device may occur if maximum values are exceeded or reverse voltage is loaded. Functional operation should be restricted to the conditions described under normal operating conditions.

## Product Specification

	Model: GKTY43SPA4R0	Rev. No.	Issued Date.	Page.
		A	2010,NOV,30	7 / 20

### 4 Touch Screen Panel Specifications

#### 4.1 Electrical Characteristics

Item	Min.	Typ.	Max.	Unit	Note
Linearity	-1.5	-	1.5	%	Analog X and Y directions
Terminal resistance	(500)	-	(1300)	$\Omega$	X (Glass side)
	(100)	-	(540)	$\Omega$	Y (Film side)
Insulation resistance	20	-	-	M $\Omega$	DC 25V
Voltage	-	5.0	7.0	V	DC
Chattering	-	-	10	ms	100k $\Omega$ pull-up

#### 4.2 Mechanical & Reliability Characteristics

Item	Min.	Typ.	Max.	Unit	Note
Activation force	60		100	g	
Durability-surface scratching	Write 100,000	-	-	characters	
Durability-surface pitting	1,000,000	-	-	touches	
Surface hardness	3	-	-	H	JIS K5400,ASTM D3363

## Product Specification

	Model: GKTY43SPA4R0	Rev. No.	Issued Date.	Page.
		A	2010,NOV,30	8 / 20

### 5 Electrical Characteristics

#### 5.1 TFT-LCD Module

(Ta=25±2°C, V<sub>DD</sub> =3.3V)

Item	Symbol	Value			Unit	Condition
		Min.	Typ.	Max.		
Power supply voltage	V <sub>DD</sub>	3.0	3.3	3.6	V	
Digital Current	I <sub>DD</sub>	-	(13)	(15)	mA	

Note (1) The specified power consumption is under the conditions at V<sub>CC</sub>=3.3V , F<sub>V</sub>=60Hz, whereas a Power dissipation check pattern below is displayed.

Black Pattern / 0 Gray

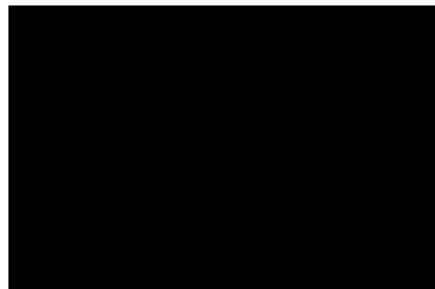

Active Area

#### 5.2 Backlight Unit

The back-light system is an edge-lighting type with white LED (Light Emitting Diode)s.

(Ta=25±2°C)

Item	Symbol	Value			Unit	Condition
		Min.	Typ.	Max.		
LED Voltage	V <sub>L</sub>	(20.3)	(22.4)	(23.8)	V	
LED Current	I <sub>f</sub>	-	(20)	-	mA	
Power Consumption	P <sub>LED</sub>	-	(448)	-	mW	(2)
LED Life Time (25°C)	-	(20000)	-	-	hr	(3)

Note (1) 7 LEDs serial type.

(2) Where I<sub>B</sub> = 20mA, V<sub>F</sub> = 22.4V, P<sub>BL</sub> = V<sub>F</sub> × I<sub>B</sub>

(3)The environmental conducted under ambient air flow ,at Ta=25±2°C,60%RH±5%



## Product Specification

	Model: GKTY43SPAH4R0	Rev. No.	Issued Date.	Page.
		A	2010,NOV,30	9 / 20

### 6 Block Diagram

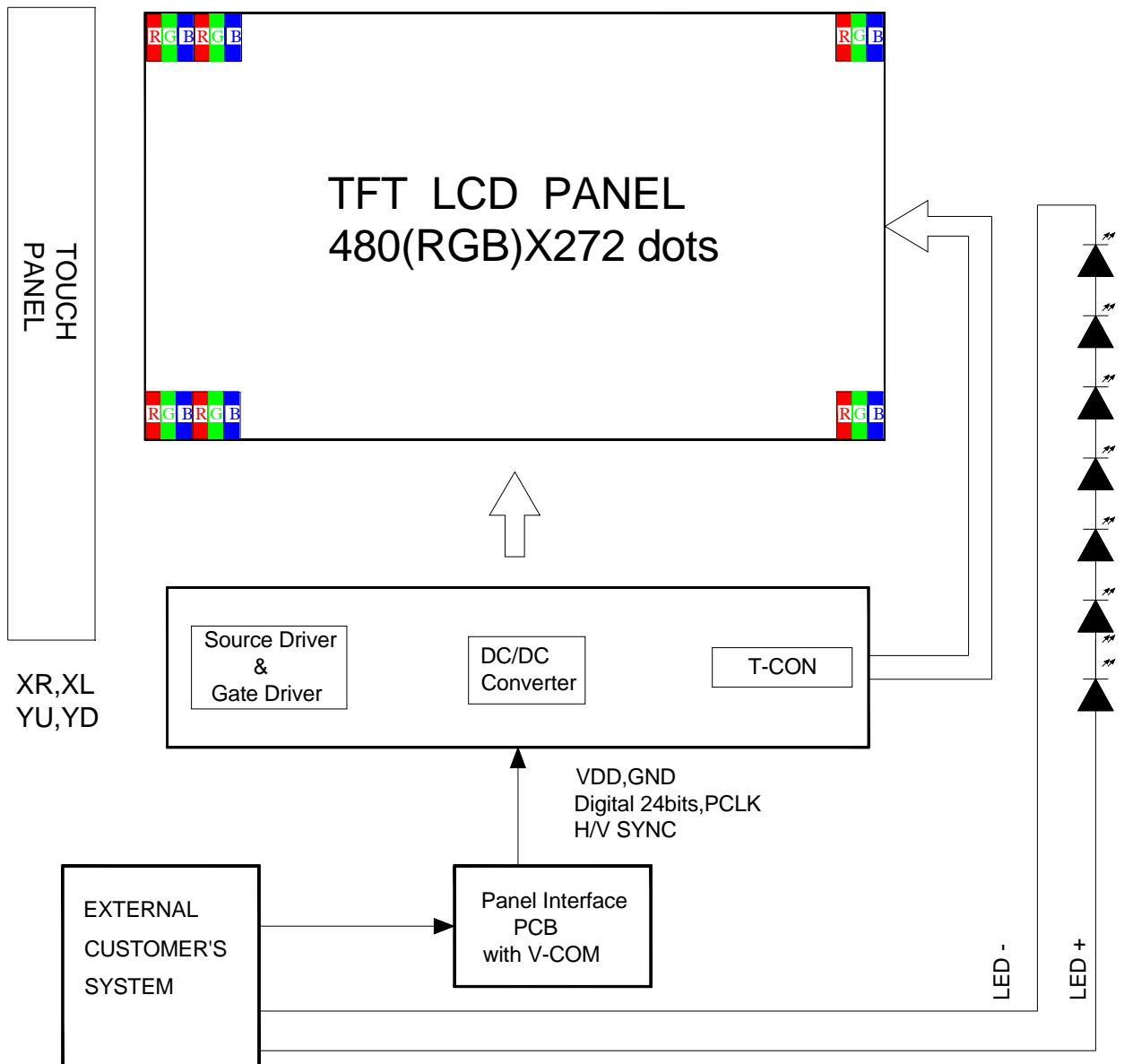

## Product Specification

	Model: GKTY43SPA4R0	Rev. No.	Issued Date.	Page.
		A	2010,NOV,30	10 / 20

### 7 Input Terminal Pin Assignment

#### 7.1 CN1 Pin Assignment

(Reference Connector: Hirose Electric Co., LTD. Product No. FH12A-40S-0.5SH(55) Top contact type)

Pin No.	Symbol	I/O	Function	Remark
1	VSS	P	Ground	
2	VSS	P	Ground	
3	DV <sub>DD</sub>	P	Logic power supply(+3.0~3.6V)	
4	DV <sub>DD</sub>	P	Logic power supply(+3.0~3.6V)	
5	R0	I	Red Data Bit 0(LSB)	
6	R1	I	Red Data Bit 1	
7	R2	I	Red Data Bit 2	
8	R3	I	Red Data Bit 3	
9	R4	I	Red Data Bit 4	
10	R5	I	Red Data Bit 5	
11	R6	I	Red Data Bit 6	
12	R7	I	Red Data Bit 7(MSB)	
13	G0	I	Green Data Bit 0(LSB)	
14	G1	I	Green Data Bit 1	
15	G2	I	Green Data Bit 2	
16	G3	I	Green Data Bit 3	
17	G4	I	Green Data Bit 4	
18	G5	I	Green Data Bit 5	
19	G6	I	Green Data Bit 6	
20	G7	I	Green Data Bit 7(MSB)	
21	B0	I	Blue Data Bit 0 (LSB)	
22	B1	I	Blue Data Bit 1	
23	B2	I	Blue Data Bit 2	
24	B3	I	Blue Data Bit 3	
25	B4	I	Blue Data Bit 4	
26	B5	I	Blue Data Bit 5	
27	B6	I	Blue Data Bit 6	
28	B7	I	Blue Data Bit 7(MSB)	
29	VSS	P	Ground	
30	P <sub>CLK</sub>	I	Dot Data Clock	
31	DISP	I	Display on/off	
32	H <sub>SYNC</sub>	I	Horizontal Sync Input	(1)

## Product Specification

	Model: GKTY43SPAH4R0	Rev. No.	Issued Date.	Page.
		A	2010,NOV,30	11 / 20

33	V <sub>SYNC</sub>	I	Vertical Sync Input	(1)
34	NC	-	No Connect	
35	XR	O	Touch Right	
36	YD	O	Touch Bottom	
37	XL	O	Touch Left	
38	YU	O	Touch Top	
39	LEDK	P	Backlight Cathode	
40	LEDA	P	Backlight Anode	

Note:

(1). Default Use SYNC MODE.

## Product Specification

	Model: GKTY43SPAH4R0	Rev. No.	Issued Date.	Page.
		A	2010,NOV,30	12 / 20

### 8 Optical Characteristics

The following items are measured under stable conditions. The optical characteristics should be measured in a dark room  
 Measuring equipment: BM-7A

(Ta=25±2°C , VDD =3.3V, If=20mA)

Item		Symbol	Condition	Min	Type	Max	Unit	Note
Brightness		--	--	(350)	(400)	--	cd/m <sup>2</sup>	--
Response time		T <sub>R</sub>	θ=0°	--	10	15	ms	--
		T <sub>F</sub>		--	20	30	ms	
Contrast ratio		CR	At optimized viewing angle	(250)	(350)	--	--	--
Color Chromaticity	Red	R <sub>X</sub>	θ=0° Normal Viewing Angle	(0.57)	(0.62)	(0.67)	--	--
		R <sub>Y</sub>		(0.29)	(0.34)	(0.39)		
	Green	G <sub>X</sub>		(0.29)	(0.34)	(0.39)	--	
		G <sub>Y</sub>		(0.52)	(0.57)	(0.62)		
	Blue	B <sub>X</sub>		(0.09)	(0.14)	(0.19)	--	
		B <sub>Y</sub>		(0.05)	(0.10)	(0.15)		
	White	W <sub>X</sub>		(0.27)	(0.32)	(0.37)	--	
		W <sub>Y</sub>		(0.29)	(0.34)	(0.39)		
Viewing Angle (6H)	Hor.	θ <sub>R</sub>	CR≥10	50	(65)		Degree	--
		θ <sub>L</sub>		50	(65)			
	Ver.	θ <sub>U</sub>		40	(50)			
		θ <sub>D</sub>		50	(60)			

## Product Specification

	Model: GKTY43SPAH4R0	Rev. No.	Issued Date.	Page.
		A	2010,NOV,30	13 / 20

a. Test equipment setup

After stabilizing and leaving the panel alone shall be warmed up for the stable operation of LCM, the measurement should be executed. Measurement should be executed in a stable, windless, and dark room. Optical specifications are measured by Topcon BM-5A/BM-7(fast) with a viewing angle of 2° at a distance of 50cm and normal direction.

b. Definition of response time: Tr and Tf

The response time is defined as the following figure and shall be measured by switching the input signal for "black" and "white".

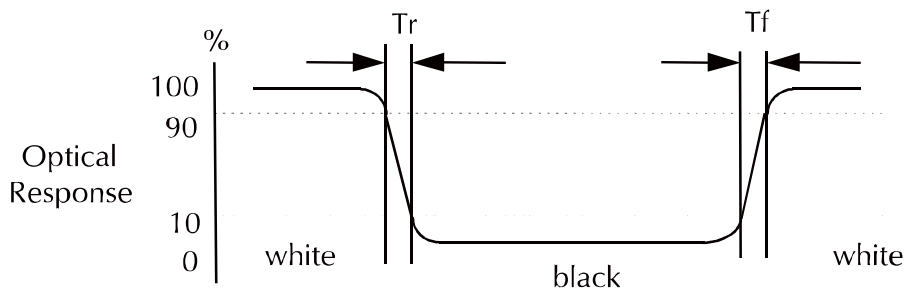

c. Definition of contrast ratio:

Brightness measured when LCD is at "white state"

$$\text{Contrast Ratio (CR)} = \frac{\text{Brightness measured when LCD is at "white state"}}{\text{Brightness measured when LCD is at "black state"}}$$

Brightness measured when LCD is at "black state"

d. Measured at the center area of the panel when all the input terminals of LCD panel are electrically opened.

## Product Specification

	Model: GKTY43SPAH4R0	Rev. No.	Issued Date.	Page.
		A	2010,NOV,30	14 / 20

e. View Angle

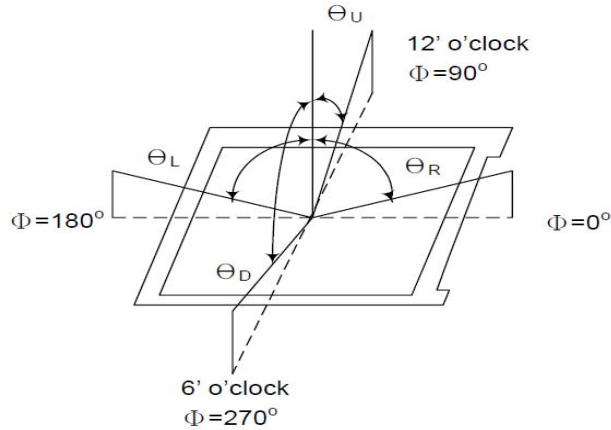

f. Definition of Luminance of White: Luminance of white at the center points

Light Source of Back-Light Unit	LED Type
---------------------------------	----------

g. Definition of White Uniformity

$$\text{White Uniformity} = \frac{\text{Min. luminance of white among 9-points}}{\text{Max. luminance of white among 9-points}} \times 100\%$$

h. The definition of Color Gamut -Color Chromaticity CIE 1931

Color coordinate of white & red, green, blue at center point.

$$\text{Color Gamut : NTSC(\%)} = (\text{RGB Triangle Area} / \text{NTSC Triangle Area}) \times 100$$

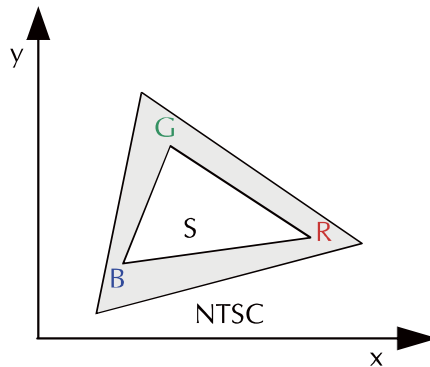

## Product Specification

	Model: GKTY43SPA4R0	Rev. No.	Issued Date.	Page.
		A	2010,NOV,30	15 / 20

### 9 Basic Display Color and Gray Scale

	Color & Gray Scale	Data Signal																							
		R7	R6	R5	R4	R3	R2	R1	R0	G7	G6	G5	G4	G3	G2	G1	G0	B7	B6	B5	B4	B3	B2	B1	B0
Basic Color	Black	0	0	0	0	0	0	0	0	0	0	0	0	0	0	0	0	0	0	0	0	0	0	0	
	Red(0)	1	1	1	1	1	1	1	1	0	0	0	0	0	0	0	0	0	0	0	0	0	0	0	
	Green(0)	0	0	0	0	0	0	0	0	1	1	1	1	1	1	1	1	0	0	0	0	0	0	0	
	Blue(0)	0	0	0	0	0	0	0	0	0	0	0	0	0	0	0	0	1	1	1	1	1	1	1	
	Cyan	0	0	0	0	0	0	0	0	1	1	1	1	1	1	1	1	1	1	1	1	1	1	1	
	Magenta	1	1	1	1	1	1	1	1	0	0	0	0	0	0	0	0	1	1	1	1	1	1	1	
	Yellow	1	1	1	1	1	1	1	1	1	1	1	1	1	1	1	1	0	0	0	0	0	0	0	
	White	1	1	1	1	1	1	1	1	1	1	1	1	1	1	1	1	1	1	1	1	1	1	1	
Red	Black	0	0	0	0	0	0	0	0	0	0	0	0	0	0	0	0	0	0	0	0	0	0		
	Red(1)	0	0	0	0	0	0	0	1	0	0	0	0	0	0	0	0	0	0	0	0	0	0		
	Red(2)	0	0	0	0	0	0	1	0	0	0	0	0	0	0	0	0	0	0	0	0	0	0		
	:	:	:	:	:	:	:	:	:	:	:	:	:	:	:	:	:	:	:	:	:	:	:		
	Red(127)	0	1	1	1	1	1	1	1	0	0	0	0	0	0	0	0	0	0	0	0	0	0		
	:	:	:	:	:	:	:	:	:	:	:	:	:	:	:	:	:	:	:	:	:	:	:		
	Red(254)	1	1	1	1	1	1	1	0	0	0	0	0	0	0	0	0	0	0	0	0	0	0		
	Red(255)	1	1	1	1	1	1	1	1	0	0	0	0	0	0	0	0	0	0	0	0	0	0		
Green	Black	0	0	0	0	0	0	0	0	0	0	0	0	0	0	0	0	0	0	0	0	0	0		
	Green(1)	0	0	0	0	0	0	0	0	0	0	0	0	0	0	1	0	0	0	0	0	0	0		
	Green(2)	0	0	0	0	0	0	0	0	0	0	0	0	0	1	0	0	0	0	0	0	0	0		
	:	:	:	:	:	:	:	:	:	:	:	:	:	:	:	:	:	:	:	:	:	:	:		
	Green(127)	0	0	0	0	0	0	0	0	0	1	1	1	1	1	1	1	0	0	0	0	0	0		
	:	:	:	:	:	:	:	:	:	:	:	:	:	:	:	:	:	:	:	:	:	:	:		
	Green(254)	0	0	0	0	0	0	0	0	1	1	1	1	1	1	1	0	0	0	0	0	0	0		
	Green(255)	0	0	0	0	0	0	0	0	1	1	1	1	1	1	1	1	0	0	0	0	0	0		
Blue	Black	0	0	0	0	0	0	0	0	0	0	0	0	0	0	0	0	0	0	0	0	0	0		
	Blue(1)	0	0	0	0	0	0	0	0	0	0	0	0	0	0	0	0	0	0	0	0	0	1		
	Blue(2)	0	0	0	0	0	0	0	0	0	0	0	0	0	0	0	0	0	0	0	0	0	1		
	:	:	:	:	:	:	:	:	:	:	:	:	:	:	:	:	:	:	:	:	:	:	:		
	Blue(127)	0	0	0	0	0	0	0	0	0	0	0	0	0	0	0	0	1	1	1	1	1	1		
	:	:	:	:	:	:	:	:	:	:	:	:	:	:	:	:	:	:	:	:	:	:	:		
	Blue(254)	0	0	0	0	0	0	0	0	0	0	0	0	0	0	0	1	1	1	1	1	1	0		
	Blue(255)	0	0	0	0	0	0	0	0	0	0	0	0	0	0	0	1	1	1	1	1	1	1		

0 : Low level voltage, 1 : High level voltage

Each basic color can be displayed in 256 gray scales from 8 bit data signals. With the combination of total 24 bit data signals, the 16,777,216-color display can be achieved on the screen.

## Product Specification

	Model: GKTY43SPA4R0	Rev. No.	Issued Date.	Page.
		A	2010,NOV,30	16 / 20

### 10 AC Timing

#### 10.1 AC Characteristics

Parameter	Symbol	Min	Typ	Max	Unit
CLK pulse duty	Tcw	40	50	60	%
Hsync width	Thw	1.0	-	-	DCLK
Hsync period	Th	55	60	65	us
Vsync setup time	Tvst	12	-	-	ns
Vsync hold time	Tvhd	12	-	-	ns
Hsync setup time	Thst	12	-	-	ns
Hsync hold time	Thhd	12	-	-	ns
Data set-up time	Tdsu	12	-	-	ns
Data hold time	Tdhd	12	-	-	ns
DE set-up time	Tdesu	12	-	-	ns
DE hold time	Tdehd	12	-	-	ns

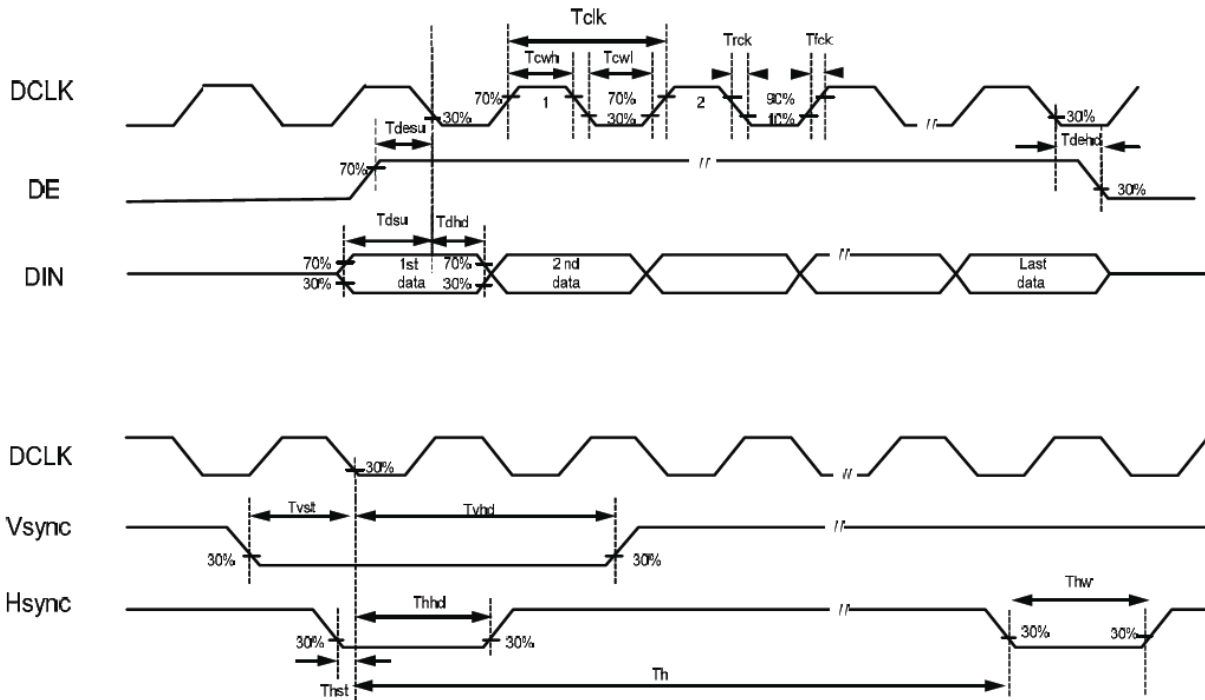



## Product Specification

	Model: GKTY43SPA4R0	Rev. No.	Issued Date.	Page.
		A	2010,NOV,30	17 / 20

### 10.2 Parallel RGB Input Timing Table (SYNC MODE)

Signal	Parameter	Symbol	Min.	Typ.	Max.	Unit.	Remark
DCLK	DCLK frequency	Fclk	5	9	12	MHz	
	DCLK period	Tclk	83	110	200	ns	
Hsync	Period Time	Th	490	531	605	DCLK	
	Display Period	Thdisp	-	480	-	DCLK	
	Back Porch	Thbp	8	43	-	DCLK	
	Front Porch	Thfp	2	8	-	DCLK	
	Pulse Width	Thw	1	-	-	DCLK	
Vsync	Period Time	Tv	275	288	335	H	
	Display Period	Tvdisp	-	272	-	H	
	Back Porch	Tvbp	2	12	-	H	
	Front Porch	Tvfp	1	4	-	H	
	Pulse Width	Tvw	1	10	-	H	

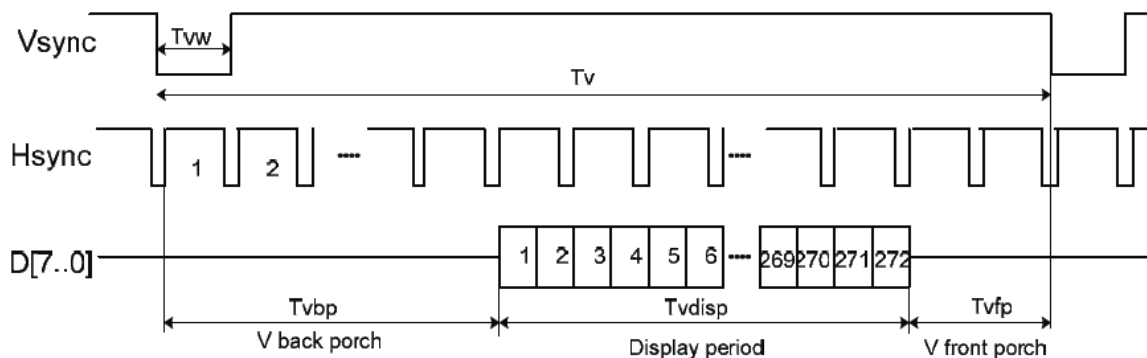
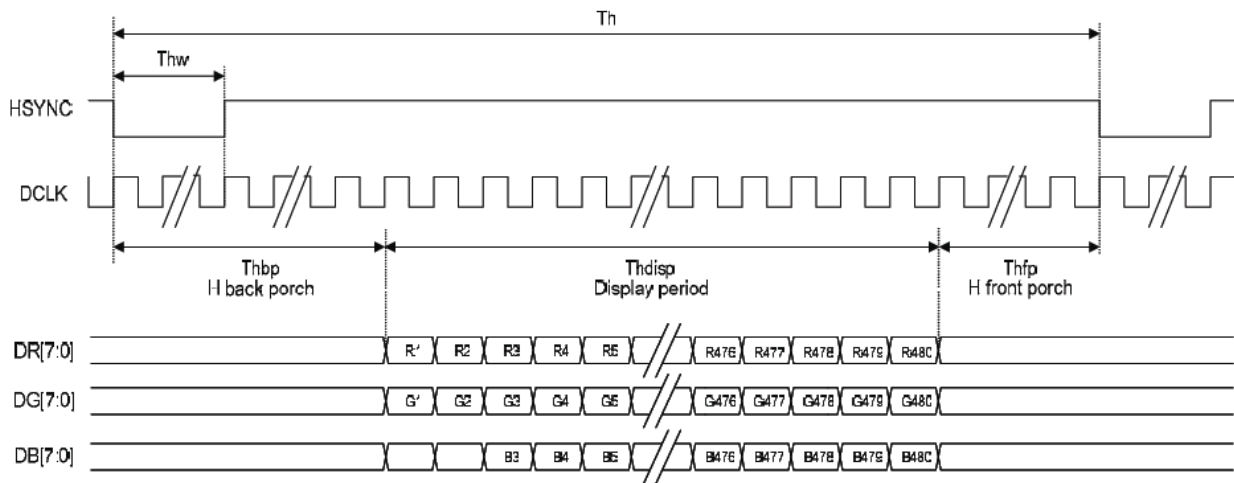

## Product Specification



Model: GKTY43SPA4R0

Rev. No.

Issued Date.

Page.

A

2010,NOV,30

18 / 20

### 10.3 POWER ON/OFF SEQUENCE

#### 10.3.1 Power ON Sequence

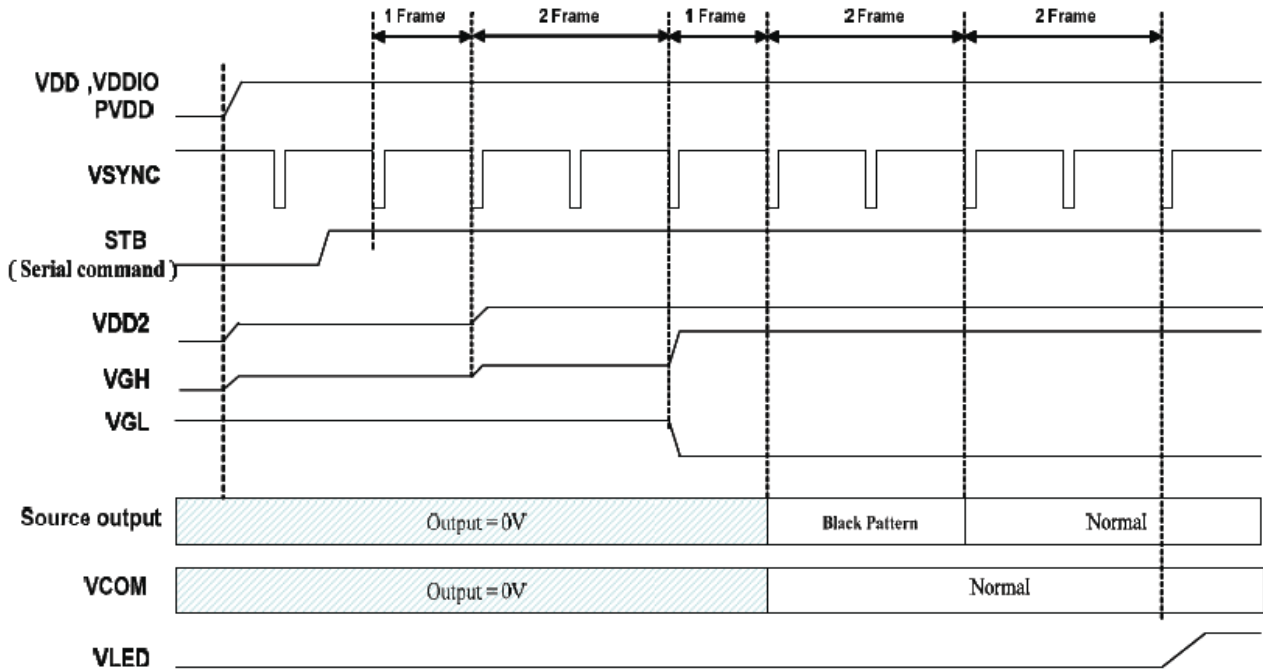

#### 10.3.2 Power OFF Sequence

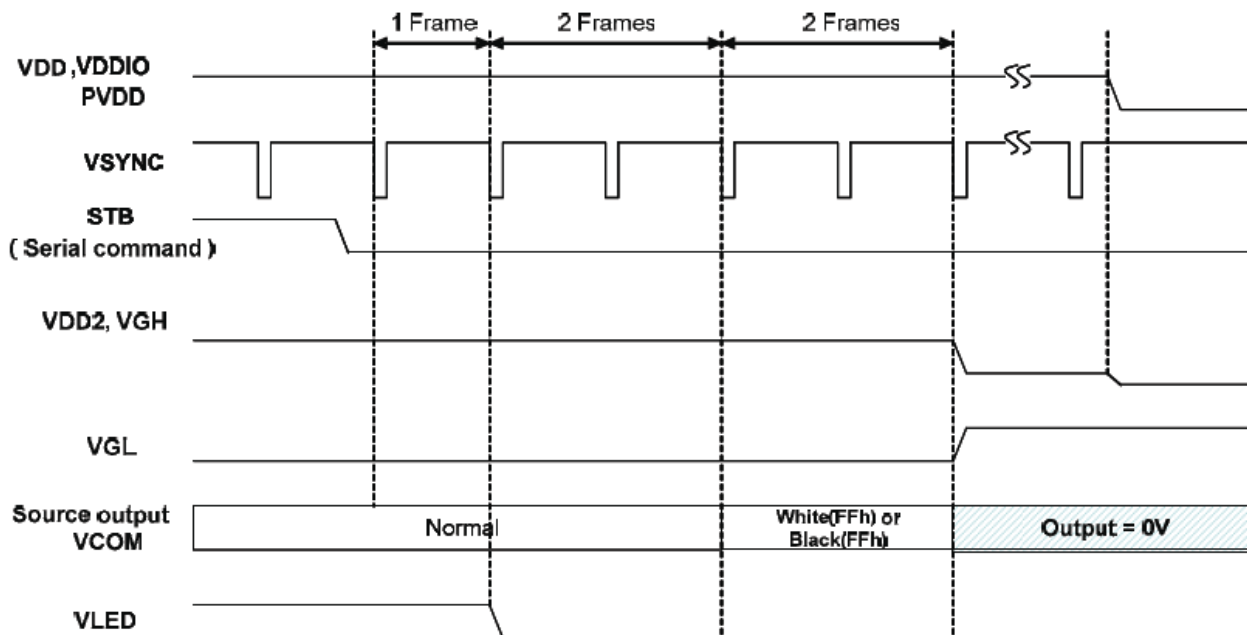

## Product Specification

	Model: GKTY43SPA4R0	Rev. No.	Issued Date.	Page.
		A	2010,NOV,30	19 / 20

### 11 Test

No change on display and in operation under the following test condition.

Condition: Unless otherwise specified, tests will be conducted under the following condition.

Temperature: 20±5°C.

Humidity: 65±5%RH.

Tests will be not conducted under functioning state.

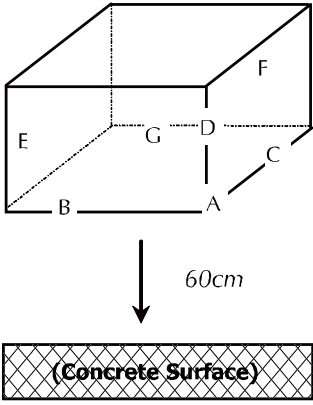
No.	Parameter	Condition	Notes
1	High Temperature Operating	70°C±2°C, 240hrs (Operation state).	
2	Low Temperature Operating	-20°C±2°C, 240hrs (Operation state).	1
3	High Temperature Storage	80°C±2°C, 240hrs.	2
4	Low Temperature Storage	-30°C±2°C, 240hrs.	1,2
5	High Temperature and High Humidity Operation Test	60°C±2°C, 90%, 240hrs	1,2
6	Vibration Test	Total fixed amplitude: 1.5mm. Vibration Frequency: 10~55Hz. One cycle 60 seconds to 3 direction of X, Y, Z each 15 minutes.	3
7.	Drop Test	To be measured after dropping from 60cm high on the concrete surface in packing state.   <p style="margin-left: 20px;"><i>Dropping method corner dropping:</i></p> <p style="margin-left: 20px;"><i>A corner: Once edge dropping.</i></p> <p style="margin-left: 20px;"><i>B, C, D edge: Once face dropping.</i></p> <p style="margin-left: 20px;"><i>E, F, G face: Once.</i></p>	

