

JANProduct Specification

	Model: GWTW50SP9G1R0	Rev. No.	Issued Date.	Page.
		A	JUL. 29, 09	1 / 20

Thin-Film-Transistor LCD Module
Model: GWTW50SP9G1R0

Acceptance

Solomon Goldentek Display Corp.
NO. 18 Ta-Yeh St., Ta-Fa Industrial Park, Ta-Liao
Hsiang, Kaohsiung Hsien 831, TAIWAN , R.O.C.
FAX: 886-7-7886800

Approved and Checked by

Approved by	Checked by		Made by
<i>David Lee</i> <i>JUL/29/09</i>		<i>David Lee</i> <i>JUL/29/09</i>	<i>Kobe Su</i> <i>JUL/29/09</i>

JANProduct Specification

	Model: GWTW50SP9G1R0	Rev. No.	Issued Date.	Page.
		A	JUL. 29, 09	2 / 20

Revise Records

Rev.	Date	Contents	Written	Approved
A	2009/07/29	Preliminary Specification	Kobe_Su	David Lee

Special Notes

Note1.	
Note2.	
Note3.	
Note4.	
Note5.	

JAN Product Specification

	Model: GWTW50SP9G1R0	Rev. No.	Issued Date.	Page.
		A	JUL. 29, 09	3 / 20

Contents

1. General Description and Features	4
1.1 Features	4
1.2 LCD Module	4
2. Mechanical Information	4
3. Electrical Specifications	5
3.1 Absolute Max. Ratings	5
3.2 Electrical Absolute Rating	5
4. Electrical Characteristics	6
4.1 TFT LCD Module	6
4 Optical Characteristics	10
5.1 Optical characteristic of the LCD	10
6 I/O Terminal	13
6.1 Pin Assignment	13
6.2 Block Diagram	14
6.3 Basic Display Color and Gray Scale	15
7 Test	16
8 Touch Screen Panel Specifications	17
8.1 Touch Screen Panel (TSP)	17
8.2 Touch Screen Panel Specifications	17
9 Appearance	18
9.1 Inspection	18
11. Dimensional Outlines	20

JAN Product Specification

	Model: GWTW50SP9G1R0	Rev. No.	Issued Date.	Page.
		A	JUL. 29, 09	4 / 20

1. General Description and Features

GWTW50SP9G1R0 is a transmissive type color active matrix TFT (Thin Film Transistor) liquid crystal display (LCD) that uses amorphous silicon TFT as a switching device. This model is composed of a TFT-LCD module, a driver circuit and a back-light unit. Graphics and texts can be displayed on a WVGA 800 (H) x 3 x 480 (V) dots with 262,144 colors by supplying 24 bits data signal (6bits/each color). The following table described the features of GWTW50SP9G1R0.

1.1 Features

- Transmissive and back-light with 14 LEDs are available.
- TN (Twisted Nematic) mode.
- 6 bits+FRC driver with 1 channel TTL interface.

1.2 LCD Module

Item	Specification	Unit
Screen Size	5.0 inches	Diagonal
Display Resolution	800 x RGB (H) x 480 (V)	Pixel
Active Area	108.0 (H) x 64.8 (V)	mm
Outline Dimension	118.5 (H) x 77.55 (V) x 4.4 (T)	mm
Display Mode	Normally white mode/ Transmissive/ Wide view	--
Surface Treatment	Anti-glare , Hard-coating (3H)	--
Pixel Arrangement	R,G,B Vertical Tripe	--
Pixel pitch	0.135 x 0.135	um
Display Color	Full Colors	--
Viewing Direction	6 o'clock	--

2. Mechanical Information

Item	Min.	Typ.	Max.	Unit	Note	
Module Size	Horizontal (H)	118.2	118.5	118.8	mm	(1,2,3)
	Vertical (V)	77.25	77.55	77.85	mm	(2)
	Thickness (T)	--	4.4	4.7	mm	(1,3)
Weight	--	(85)	--	g	--	

Note (1) Not include FPC. Refer to the Outline Dimension Drawing as attached.

(2) Back-light unit is included.

(3) Excluding backlight cables.

JAN Product Specification

	Model: GWTW50SP9G1R0	Rev. No.	Issued Date.	Page.
		A	JUL. 29, 09	5 / 20

3. Electrical Specifications

3.1 Absolute Max. Ratings

3.1.1 Absolute Ratings of Environment

If the operating condition exceeds the following absolute maximum ratings, the TFT LCD module may be damaged permanently.

(Ta=25±2°C, V_{SS}=GND=0)

Item	Symbol	Min.	Max.	Unit	Note
Storage temperature	T _{STG}	-30	80	°C	(1)
Operating temperature	T _{OPR}	-20	70	°C	(1,2,3)

Note (1) 95 % RH Max. (40 °C ≥ Ta). Maximum wet-bulb temperature at 39 °C or less. (Ta > 40 °C) No condensation.

Note (2) In case of below 0°, the response time of liquid crystal (LC) becomes slower and the color of panel becomes darker than normal one. Level of retardation depends on temperature, because of LC's character

Note (3) Only operation is guaranteed at operating temperature. Contrast, response time, another display quality are evaluated at +25°C.

3.2 Electrical Absolute Rating

3.2.1 TFT LCD Module

Parameter	Symbol	Min.	Max.	Unit	Remark
Power supply voltage	V _{DD}	-0.5	5.0	V	--
Signal input voltage	V _i	-0.3	V _{DD} +0.3	V	--

3.2.2 Back-Light Unit

The Back-light system is an edge-lighting type with 14 white LED(Light Emitting Diode)s. The characteristics of 14 white LEDs are shown in the following tables.

(Ta= Room Temp)

Characteristics	Symbol	Min.	Typ.	Max.	Unit	Note
Current	I _L	-	40	-	mA	(1)
Voltage	V _L	-	23.1	-	V	(2)
Operating LED life time	Hr	10000	-	-	Hour	

Note (1) LEDs in 7 series x 2 parallel type.

(2) Where I_L= 40mA, V_L = 23.1

JAN Product Specification

	Model: GWTW50SP9G1R0	Rev. No.	Issued Date.	Page.
		A	JUL. 29, 09	6 / 20

4. Electrical Characteristics

4.1 TFT LCD Module

GND=0V

Item	Symbol	Min.	Typ.	Max.	Unit	Remark
Power supply	V_{DD}	3.0	3.3	3.6	V	
Input signal voltage	V_{iH}	0.7VDD	-	VDD	V	Note 1
	V_{iL}	GND	-	0.3VDD	V	Note 1
Power Supply current	I_{DD}	-	TBD	-	mA	$V_{DD}=3.3V$

Note1: HSYNC , VSYNC ,DE ,R/G/B Data

4.2 Ac Characteristics

Parameter	Symbol	Min.	Typ.	Max.	Unit.	Remark
DCLK cycle time	Tclk	25			ns	
DCLK frequency	fclk		33	40	MHZ	
DCLK pulse duty	Tcwh	40	50	60	%	
VSYNC setup time	Tvst	8			ns	
VSYNC hold time	Tvhd	8			ns	
HSYNC setup time	Thst	8			ns	
HSYNC hold time	Thhd	8			ns	
Data setup time	Tdasu	8			ns	
Data hold time	Tdahd	8			ns	
DE setup time	Tdesu	8			ns	
DE hold time	Tdehd	8			ns	
Horizontal display area	Thd		800		Tcph	
HSYNC Period time	Th		928		Tcph	
HSYNC width	Thwh	1	48		Tcph	
HSYNC back porch	Thbp		40		Tcph	
HSYNC front porch	Thfp		40		th	
Vertical display area	Tvd		480		th	
VSYNC period time	Tv		525		th	
VSYNC width	Tvwh		3		th	
VSYNC back porch	Tvbp		29		th	
VSYNC front porch	Tvfp		13		th	

JAN Product Specification



Model: GWTW50SP9G1R0

Rev. No.

Issued Date.

Page.

A

JUL. 29, 09

7 / 20

4.3 Timing Diagram of Interface Signal

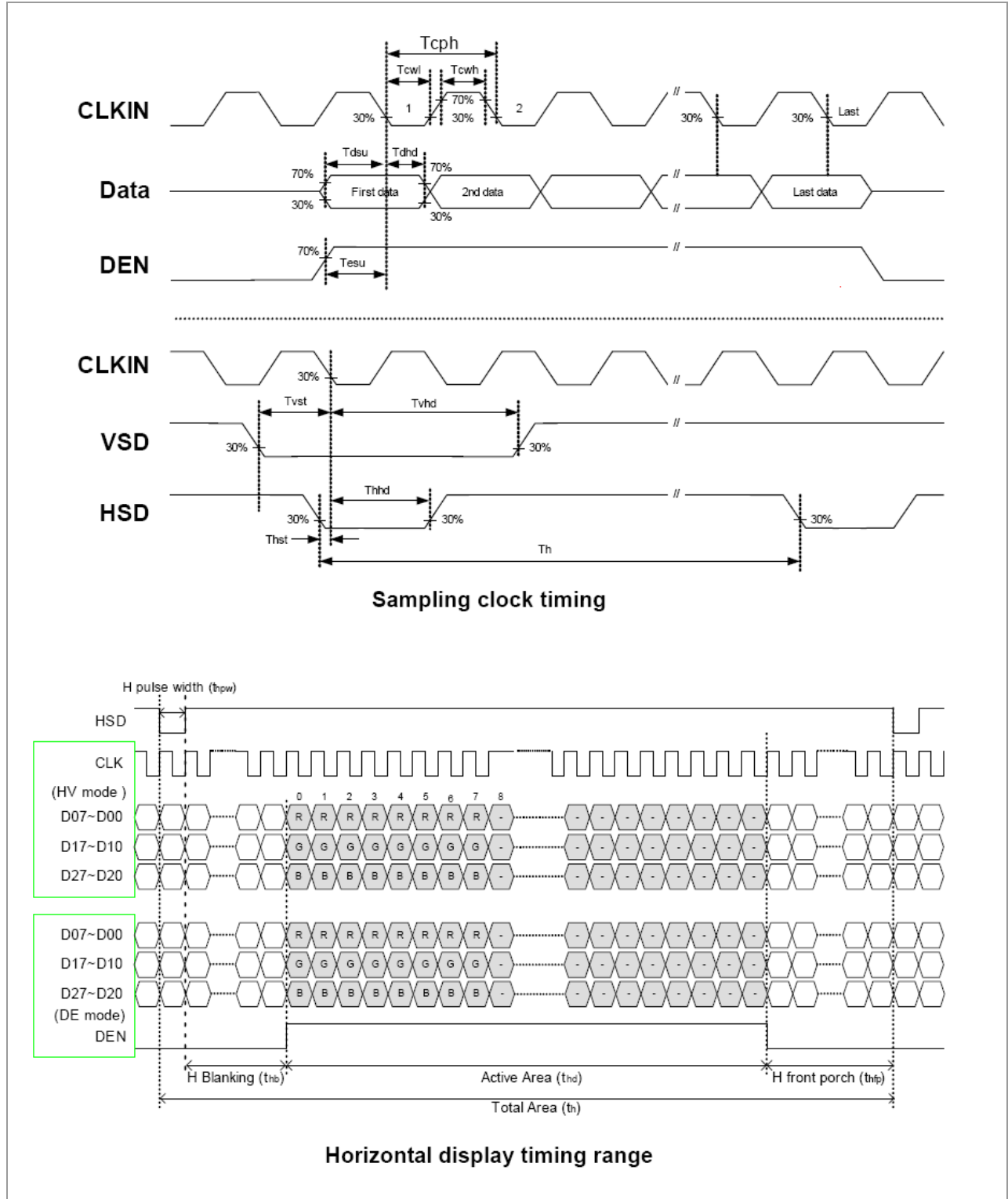

JAN Product Specification



Model: GWTW50SP9G1R0	Rev. No.	Issued Date.	Page.
	A	JUL. 29, 09	8 / 20

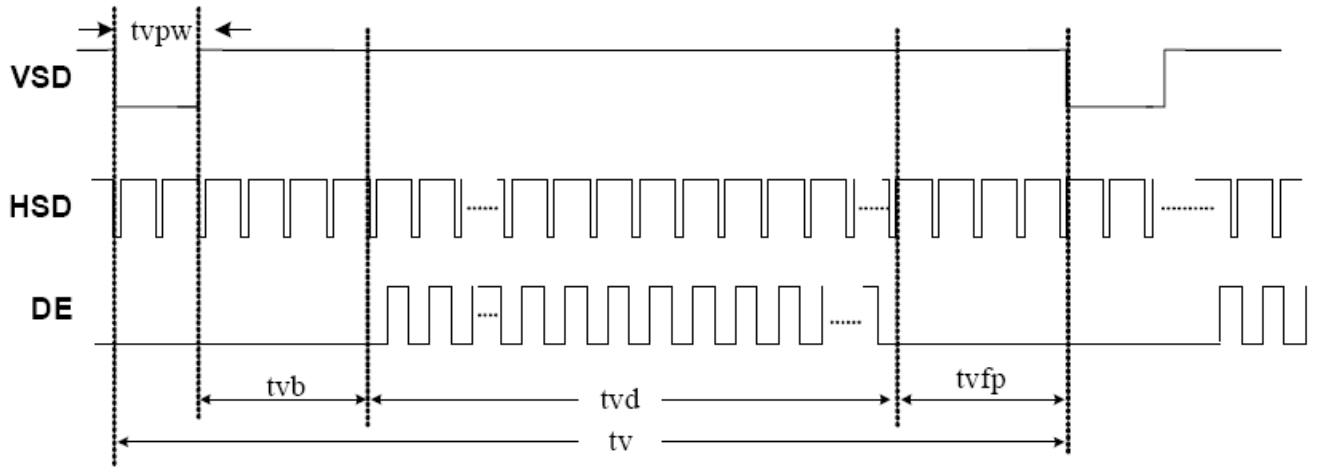

Vertical timing

4.4 Power Sequence

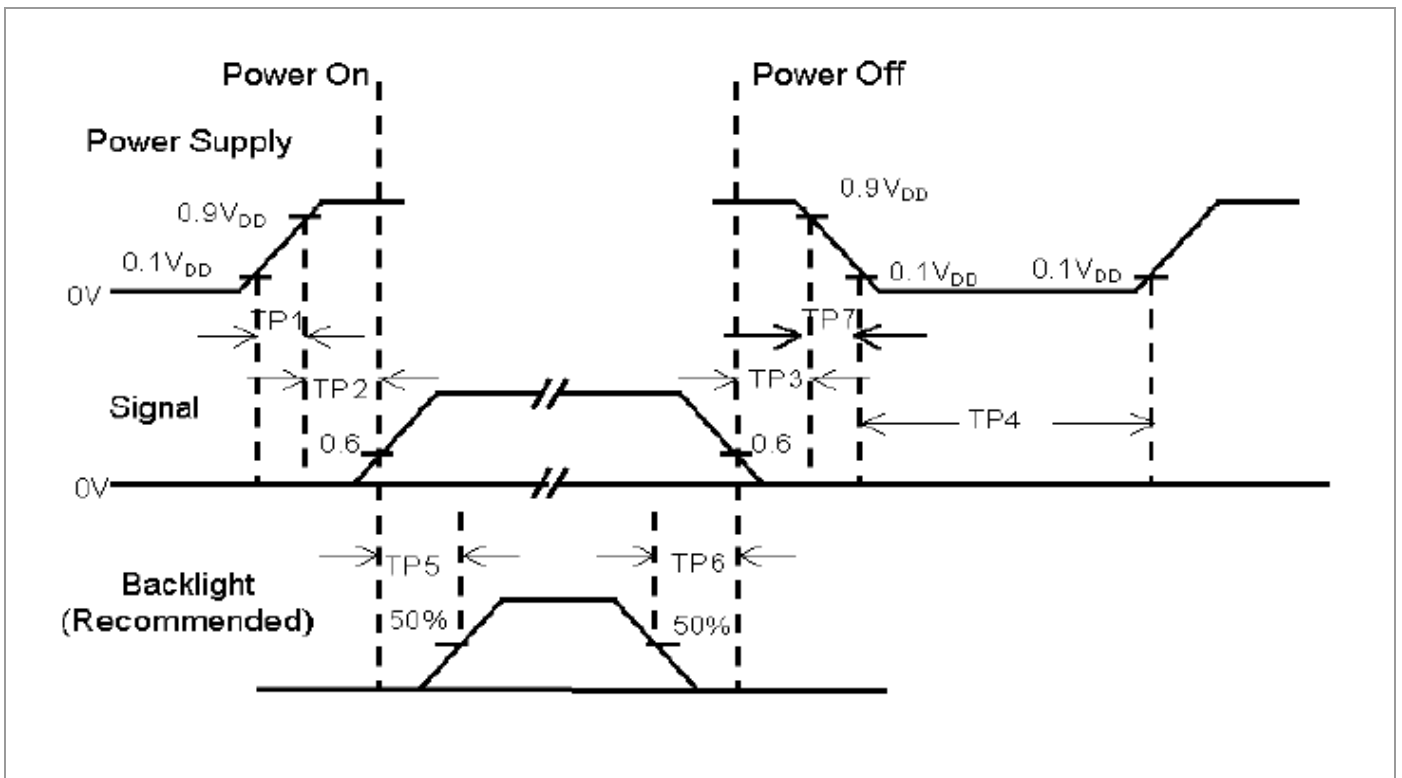

JAN Product Specification

	Model: GWTW50SP9G1R0	Rev. No.	Issued Date.	Page.
		A	JUL. 29, 09	9 / 20

Item	Min.	Typ.	Max.	Unit	Remark
TP1	0.5	-	10	msec	
TP2	0	-	50	msec	
TP3	0	-	50	msec	
TP4	1000	-	-	msec	
TP5	200	-	-	msec	
TP6	200	-	-	msec	
TP7	0.5	-	10	msec	

- Note : (1) The supply voltage of the external system for the module input should be the same as the Definition of V_{DD} .
- (2) Apply the lamp voltage within the LCD operation range. When the back-light turns on before the LCD operation or the LCD turns off before the back-light turns off, the display may momentarily become white.
- (3) In case of V_{DD} =off level, please keep the level of input signal on the low or keep a high impedance.
- (4) TP4 should be measured after the module has been fully discharged between power off and on period.
- (5) Interface signal shall not be kept at high impedance when the power is on.

JAN Product Specification

	Model: GWTW50SP9G1R0	Rev. No.	Issued Date.	Page.
		A	JUL. 29, 09	10 / 20

4 Optical Characteristics

5.1 Optical characteristic of the LCD

The following items are measured under stable conditions. The optical characteristics should be measured in a dark room or equivalent state.

Measuring equipment: BM-5A, BM-7A

Item	Symbol	Condition	Min	Type	Max	Unit	Note
Brightness			(260)	(320)	--	cd/m ²	
Response time	T _r	θ=0°	--	(2)	(4)	ms	.
	T _f		--	(6)	(12)	ms	
Contrast ratio	CR	At optimized viewing angle	(480)	(600)	--	cd/m ²	
Color Gamut	NTSC %	--	70	--	--	%	
Color Chromaticity (CIE 1931)	White	W _x	(0.260)	(0.310)	(0.360)	--	
		W _y	(0.280)	(0.330)	(0.380)		
Viewing Angle (6H)	Hor.	θ _R	CR≥10	65	75	--	Degree
		θ _L		65	75	--	
	Ver.	φ _H		50	60	--	
		φ _L		60	70	--	

JAN Product Specification

	Model: GWTW50SP9G1R0	Rev. No.	Issued Date.	Page.
		A	JUL. 29, 09	11 / 20

a. Test equipment setup

After stabilizing and leaving the panel alone shall be warmed up for the stable operation of LCM, the measurement should be executed. Measurement should be executed in a stable, windless, and dark room. Optical specifications are measured by Topcon BM-7A(fast) with a viewing angle of 2° at a distance of 50cm and normal direction.

b. Definition of response time: Tr and Tf

The response time is defined as the following figure and shall be measured by switching the input signal for "black" and "white".

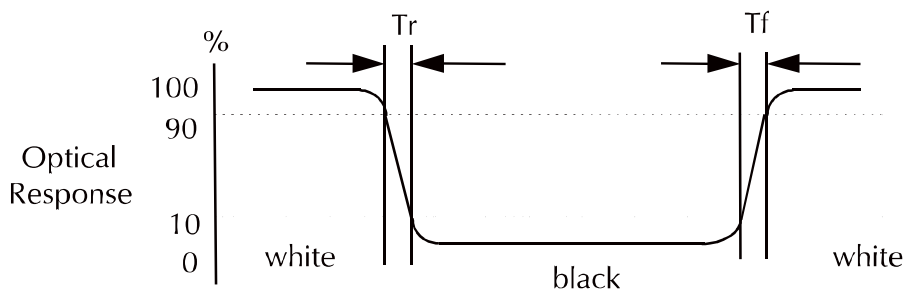

c. Definition of contrast ratio:

$$\text{Contrast Ratio (CR)} = \frac{\text{Brightness measured when LCD is at "white state"}}{\text{Brightness measured when LCD is at "black state"}}$$

d. Measured at the center area of the panel when all the input terminals of LCD panel are electrically opened.

JAN Product Specification

	Model: GWTW50SP9G1R0	Rev. No.	Issued Date.	Page.
		A	JUL. 29, 09	12 / 20

e. View Angle

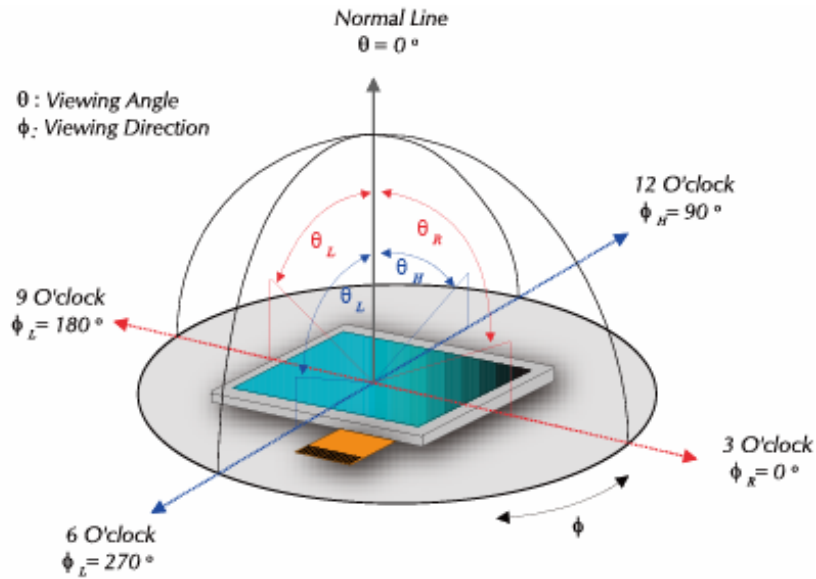

f. Definition of Luminance of White: Luminance of white at the center points

Light Source of Back-Light Unit	LED Type
---------------------------------	----------

g. Definition of White Uniformity

$$\text{White Uniformity} = \frac{\text{Min. luminance of white among 5-points}}{\text{Max. luminance of white among 5-points}}$$

h. The definition of Color Gamut -Color Chromaticity CIE 1931

Color coordinate of white & red, green, blue at center point.

Color Gamut : NTSC(%) = (RGB Triangle Area / NTSC Triangle Area) x 100

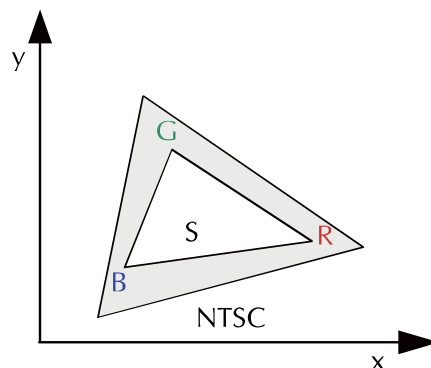

JAN Product Specification

	Model: GWTW50SP9G1R0	Rev. No.	Issued Date.	Page.
		A	JUL. 29, 09	13 / 20

6 I/O Terminal

6.1 Pin Assignment

Pin No.	Symbol	I/O	Function	Remark
1	VLED-	P	Power for LED backlight cathode	
2	VLED+	P	Power for LED backlight anode	
3	GND	P	Power ground	
4	VDD	P	Power voltage	
5	R0	I	Red data(LSB)	
6	R1	I	Red data	
7	R2	I	Red data	
8	R3	I	Red data	
9	R4	I	Red data	
10	R5	I	Red data	
11	R6	I	Red data	
12	R7	I	Red data(MSB)	
13	G0	I	Green data(LSB)	
14	G1	I	Green data	
15	G2	I	Green data	
16	G3	I	Green data	
17	G4	I	Green data	
18	G5	I	Green data	
19	G6	I	Green data	
20	G7	I	Green data(MSB)	
21	B0	I	Blue data(LSB)	
22	B1	I	Blue data	
23	B2	I	Blue data	
24	B3	I	Blue data	
25	B4	I	Blue data	
26	B5	I	Blue data	
27	B6	I	Blue data	
28	B7	I	Blue data(MSB)	
29	DGND	I	Digital ground	
30	DCLK	I	Pixel clock	
31	DISP	I	Display on/off	
32	HSYNC	I	Horizontal sync signal	
33	VSYNC	I	Vertical sync signal	
34	DE	I	Data enable	
35	NC	-	Test Pin	
36	GND	P	Power ground	
37	X_R	I/O	Right electrode - differential analog	
38	Y_B	I/O	Bottom electrode - differential analog	
39	X_L	I/O	Left electrode - differential analog	
40	Y_T	I/O	Top electrode - differential analog	

I/O: I: input, O: output ,P: power

JAN Product Specification



Model: GWTW50SP9G1R0

Rev. No.

Issued Date.

Page.

A

JUL. 29, 09

14 / 20

6.2 Block Diagram

6.2.1 TFT LCD Module

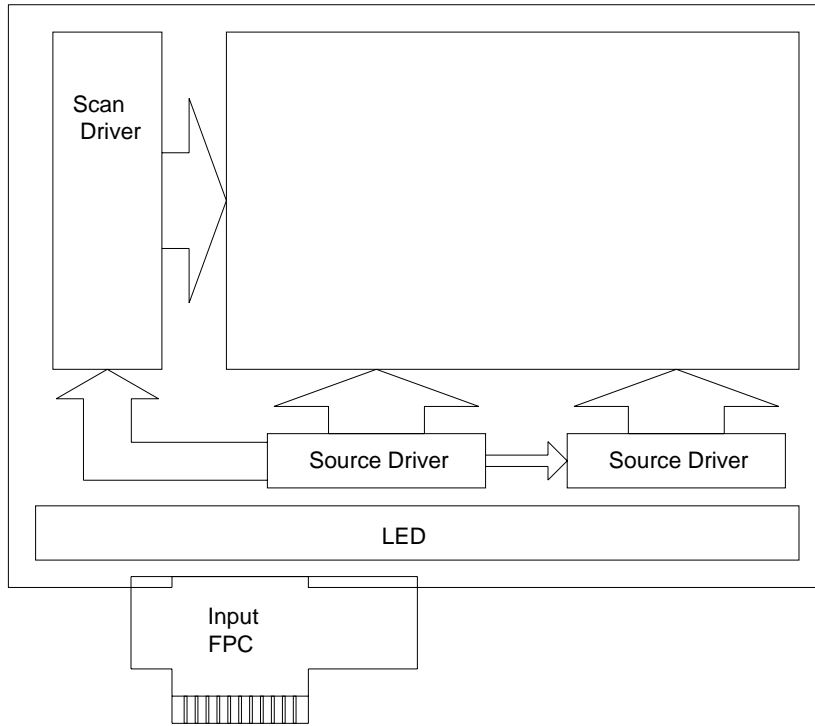

6.2.2 Pixel Format

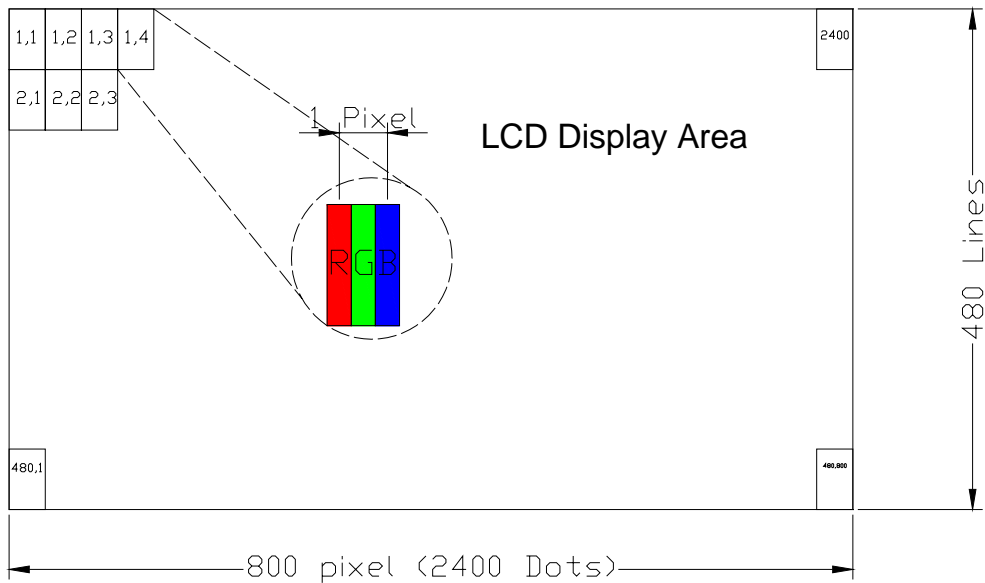

JAN Product Specification

	Model: GWTW50SP9G1R0	Rev. No.	Issued Date.	Page.
		A	JUL. 29, 09	15 / 20

6.3 Basic Display Color and Gray Scale

	Color & Gray Scale	Data Signal																							
		R7	R6	R5	R4	R3	R2	R1	R0	G7	G6	G5	G4	G3	G2	G1	G0	B7	B6	B5	B4	B3	B2	B1	B0
Basic Color	Black	0	0	0	0	0	0	0	0	0	0	0	0	0	0	0	0	0	0	0	0	0	0	0	0
	Red(0)	1	1	1	1	1	1	1	1	0	0	0	0	0	0	0	0	0	0	0	0	0	0	0	0
	Green(0)	0	0	0	0	0	0	0	0	1	1	1	1	1	1	1	1	0	0	0	0	0	0	0	0
	Blue(0)	0	0	0	0	0	0	0	0	0	0	0	0	0	0	0	0	1	1	1	1	1	1	1	1
	Cyan	0	0	0	0	0	0	0	0	1	1	1	1	1	1	1	1	1	1	1	1	1	1	1	1
	Magenta	1	1	1	1	1	1	1	1	0	0	0	0	0	0	0	0	1	1	1	1	1	1	1	1
	Yellow	1	1	1	1	1	1	1	1	1	1	1	1	1	1	1	1	0	0	0	0	0	0	0	0
	White	1	1	1	1	1	1	1	1	1	1	1	1	1	1	1	1	1	1	1	1	1	1	1	1
Red	Black	0	0	0	0	0	0	0	0	0	0	0	0	0	0	0	0	0	0	0	0	0	0	0	0
	Red(1)	0	0	0	0	0	0	0	1	0	0	0	0	0	0	0	0	0	0	0	0	0	0	0	0
	Red(2)	0	0	0	0	0	0	1	0	0	0	0	0	0	0	0	0	0	0	0	0	0	0	0	0
	:	:	:	:	:	:	:	:	:	:	:	:	:	:	:	:	:	:	:	:	:	:	:	:	:
	Red(31)	0	1	1	1	1	1	1	1	0	0	0	0	0	0	0	0	0	0	0	0	0	0	0	0
	:	:	:	:	:	:	:	:	:	:	:	:	:	:	:	:	:	:	:	:	:	:	:	:	:
	Red(62)	1	1	1	1	1	1	1	0	0	0	0	0	0	0	0	0	0	0	0	0	0	0	0	0
	Red(63)	1	1	1	1	1	1	1	1	0	0	0	0	0	0	0	0	0	0	0	0	0	0	0	0
Green	Black	0	0	0	0	0	0	0	0	0	0	0	0	0	0	0	0	0	0	0	0	0	0	0	0
	Green(1)	0	0	0	0	0	0	0	0	0	0	0	0	0	0	0	1	0	0	0	0	0	0	0	0
	Green(2)	0	0	0	0	0	0	0	0	0	0	0	0	0	0	1	0	0	0	0	0	0	0	0	0
	:	:	:	:	:	:	:	:	:	:	:	:	:	:	:	:	:	:	:	:	:	:	:	:	:
	Green(31)	0	0	0	0	0	0	0	0	0	1	1	1	1	1	1	1	0	0	0	0	0	0	0	0
	:	:	:	:	:	:	:	:	:	:	:	:	:	:	:	:	:	:	:	:	:	:	:	:	:
	Green(62)	0	0	0	0	0	0	0	0	1	1	1	1	1	1	1	0	0	0	0	0	0	0	0	0
	Green(63)	0	0	0	0	0	0	0	0	1	1	1	1	1	1	1	1	0	0	0	0	0	0	0	0
Blue	Black	0	0	0	0	0	0	0	0	0	0	0	0	0	0	0	0	0	0	0	0	0	0	0	0
	Blue(1)	0	0	0	0	0	0	0	0	0	0	0	0	0	0	0	0	0	0	0	0	0	0	0	1
	Blue(2)	0	0	0	0	0	0	0	0	0	0	0	0	0	0	0	0	0	0	0	0	0	0	1	0
	:	:	:	:	:	:	:	:	:	:	:	:	:	:	:	:	:	:	:	:	:	:	:	:	:
	Blue(31)	0	0	0	0	0	0	0	0	0	0	0	0	0	0	0	0	1	1	1	1	1	1	1	1
	:	:	:	:	:	:	:	:	:	:	:	:	:	:	:	:	:	:	:	:	:	:	:	:	:
	Blue(62)	0	0	0	0	0	0	0	0	0	0	0	0	0	0	0	1	1	1	1	1	1	1	1	0
	Blue(63)	0	0	0	0	0	0	0	0	0	0	0	0	0	0	0	1	1	1	1	1	1	1	1	1

Each basic color can be displayed in 64 gray scales from 6 bit data signals. With the combination of total 18 bit data signals, the 262,144-color display can be achieved on the screen.

JAN Product Specification

	Model: GWTW50SP9G1R0	Rev. No.	Issued Date.	Page.
		A	JUL. 29, 09	16 / 20

7 Test

No change on display and in operation under the following test condition.

Condition: Unless otherwise specified, tests will be conducted under the following condition.

Temperature: 20±5°C.

Humidity: 65±5%RH.

Tests will be not conducted under functioning state.

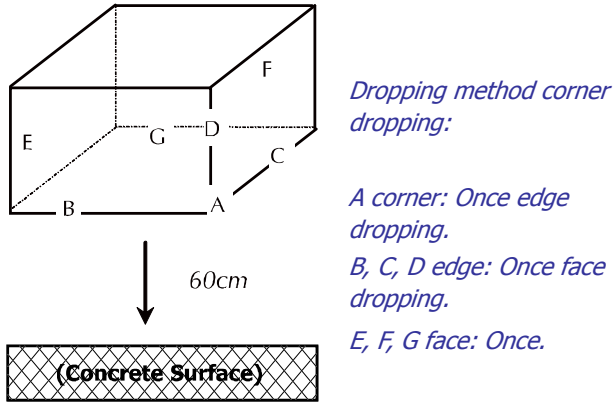
No.	Parameter	Condition	Notes
1	High Temperature Operating	60°C±2°C, 120hrs (Operation state).	
2	Low Temperature Operating	-10°C±2°C, 120hrs (Operation state).	1
3	High Temperature Storage	70°C±2°C, 120hrs.	2
4	Low Temperature Storage	-20°C±2°C, 120hrs.	1,2
5	Damp Proof Test	40°C±2°C, 90~95%, 120hrs.	1,2
6	Vibration Test	Total fixed amplitude: 1.5mm. Vibration Frequency: 10~55Hz. One cycle 60 seconds to 3 direction of X, Y, Z each 15 minutes.	3
7.	Shock Test	To be measured after dropping from 60cm high on the concrete surface in packing state.  <p style="margin-left: 20px;"><i>Dropping method corner dropping:</i></p> <p style="margin-left: 20px;"><i>A corner: Once edge dropping.</i></p> <p style="margin-left: 20px;"><i>B, C, D edge: Once face dropping.</i></p> <p style="margin-left: 20px;"><i>E, F, G face: Once.</i></p>	

- Notes:
1. No dew condensation to be observed.
 2. The function test shall be conducted after 4 hours storage at the normal temperature and humidity after removed from the test chamber.
 3. Vibration test will be conducted to the product itself without putting I in a container.

JAN Product Specification

	Model: GWTW50SP9G1R0	Rev. No.	Issued Date.	Page.
		A	JUL. 29, 09	17 / 20

8 Touch Screen Panel Specifications

8.1 Touch Screen Panel (TSP)

Pin No.	Symbol	I/O	Function
1	X1	Right	Right electrode – differential analog
2	Y1	Bottom	Bottom electrode – differential analog
3	X2	Left	Left electrode – differential analog
4	Y2	Top	Top electrode – differential analog

8.2 Touch Screen Panel Specifications

8.2.1 Electrical Characteristics

Item	Min.	Typ.	Max.	Unit	Note
Linearity	-	-	1.5	%	Analog X and Y directions
Terminal resistance	100	-	900	Ω	X (Film side)
	100	-	900	Ω	Y (Glass side)
Insulation resistance	20	-	-	M Ω	DC 25V
Voltage	-	5.0	7.0	V	DC
Chattering	-	-	10	ms	100k Ω pull-up
Transparency	-	80	-	%	JIS K5400

8.2.2 Mechanical & Reliability Characteristics

Item	Min.	Typ.	Max.	Unit	Note
Activation force	80	-	-	g	(1)
Durability-surface scratching	Write 100,000	-	-	Characters	-
Durability-surface pitting	1,000,000	-	-	touches	-
Surface hardness	3	-	-	H	3H pencil, pressure 1N/45°, (JIS K5400)
Joule impact	13.0 ϕ Dia. Steel Ball/9g, Height=30cm 1 time, no damage. [Impact at center area]				

Note (1) Input in Stylus : with R8.0mm silicone rubber, 250g, 3 times/sec

JAN Product Specification

	Model: GWTW50SP9G1R0	Rev. No.	Issued Date.	Page.
		A	JUL. 29, 09	18 / 20

9 Appearance

9.1 Inspection

The distance between the eyes and the sample shall be more than 30cm. All directions for inspecting the sample should be within 45° against perpendicular line.

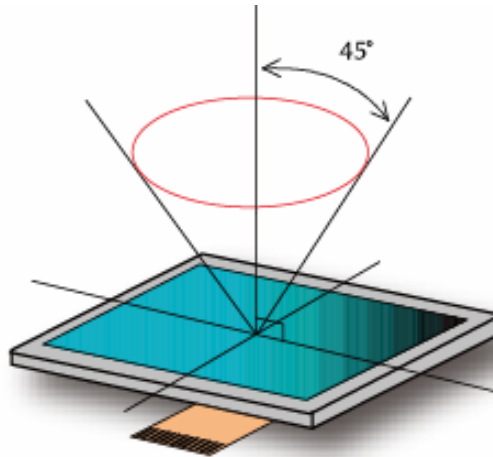

Definition of Applicable Zones

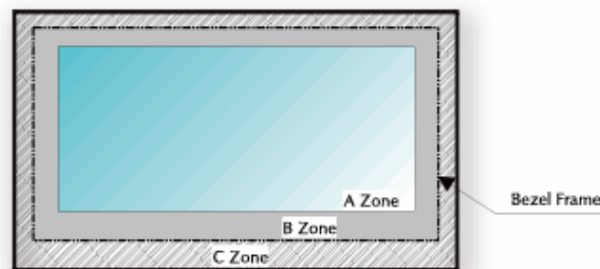

A Zone : Active display area, B Zone : Area from outside of "A Zone" to validity viewing area

C Zone : Rest parts, A Zone + B Zone = Validity viewing area

(a) Operating Inspection

The function and appearance shall be inspected in the condition of

- under 750 lx or over light Reflective Type.
- Using over Backlight unit Transflective Type, Transmissive Type

Condition of judgment

In case of no gradation display it judges by applied On/Off voltage or optimal contrast.

In case of gradation display it judges by contrast that the bad point is able to confirm best.

(b) Appearance Inspection

The appearance shall be inspected in the condition of

- under 500 lx or over light Reflective Type.
- Using over Backlight unit Transflective Type, Transmissive Type

(c) Inspection Environment

Inspection environment it carried out with 250 lx or less in principles.

JAN Product Specification

	Model: GWTW50SP9G1R0	Rev. No.	Issued Date.	Page.
		A	JUL. 29, 09	19 / 20

10 Arranty

This product has been manufactured to your company's specifications as a part for use in your company's general electronic products. It is guaranteed to perform according to delivery specifications. For any other use apart from general electronic equipment, we cannot take responsibility if the product is used in medical devices, nuclear power control equipment, aerospace equipment, fire and security systems, or any other applications in which there is a direct risk to human life and where extremely high levels of reliability are required. If the product is to be used in any of the above applications, we will need to enter into a separate product liability agreement.

- 1 We cannot accept responsibility for any defect, which may arise from additional manufacturing of the product (including disassembly and reassembly), after product delivery.
- 2 We cannot accept responsibility for any defect, which may arise after the application of strong external force to the product.
- 3 We cannot accept responsibility for any defect, which may arise due to the application of static electricity after the product has passed your company's acceptance inspection procedures.
- 4 We cannot accept responsibility for industrial property, which may arise through the use of your product, with exception to those issues relating directly to the structure or method of manufacturing of our product. SGD-origin longer than one year from SGD production.

JAN Product Specification



Model: GWTW50SP9G1R0

Rev. No.

Issued Date.

Page.

A

JUL. 29, 09

20 / 20

11. Dimensional Outlines

